

ICF Connectors



The ICF Ledger Connector System is engineered to solve the challenges of mounting wood or steel ledgers to walls built with insulated concrete forms (ICF). This flier provides information on the various products we have to serve the ICF market.

The ICFVL is a 14-gauge galvanized steel connector designed to provide both vertical and lateral in-plane resistance. The embedded legs are embossed for additional stiffness and the holes allow for concrete to flow through and around the connector. The exposed flange on the face of the ICF provides a structural surface for mounting either a wood or steel ledger.

See the current Simpson Strong-Tie® *Wood Construction Connectors* catalog or www.strongtie.com for additional information.



INSTALLATION OF ICFVL:

- Snap a line for the bottom of the ledger and mark the on-center spacing
- Use the ICFVL to mark the kerf locations in the ICF
- Cut the kerfs as marked
- Insert the ICFVL flush to the face of the ICF
- Place concrete (min. $f'_c = 2500$ psi).



Installation tip: Use a screw through diamond hole in face of ICFVL and into web to hold in place during concrete pour (remove prior to ledger installation).

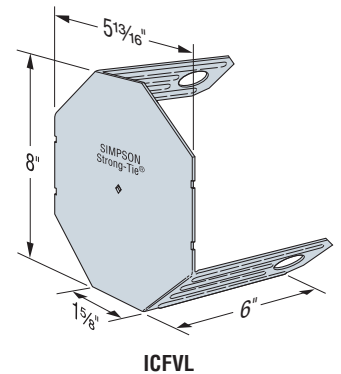

ATTACHMENT OF WOOD LEDGER

- Slip the appropriate ledger connector underneath the wood ledger (as shown)
- Install the eight ICF-D3.62 screws partially into the ledger
- Position the ledger level to the chalk line and drive the screws through the wood and into the ICFVL
- All screws should be located at least $\frac{1}{2}$ " from the edge of the ICFVL

Note: Do not splice at the ICFVL-W or ICFVL-CW location.



ATTACHMENT OF STEEL LEDGER

- Position the ledger level to the chalk line and drive the required number of screws through the steel ledger and into the ICFVL
- All screws should be located at least $\frac{1}{2}$ " from the edge of the ICFVL
- Space screws evenly

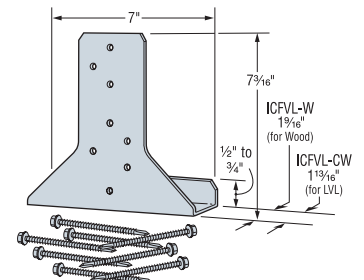

ICFVL-W and ICFVL-CW

800-999-5099
www.strongtie.com

© 2010 Simpson Strong-Tie Company Inc.

Printed in the U.S.A.

F-ICFVL10 9/10 exp. 4/13 6/13

ICF Connectors

- 1 Use MAB15Z or MAB23Z
- 2 Attach interior partition walls with 1/4-14 #3 drill point screws (sold separately) into ICFVL where needed
- 3 Use ICFVL to attach ledger to ICF
- 4 Use ICFVL-W for solid sawn lumber or ICFVL-CW for LVL.
NOTE: See drawing below for detail on double 2x ledger
- 5 Use IUS hanger for I-joist floor system

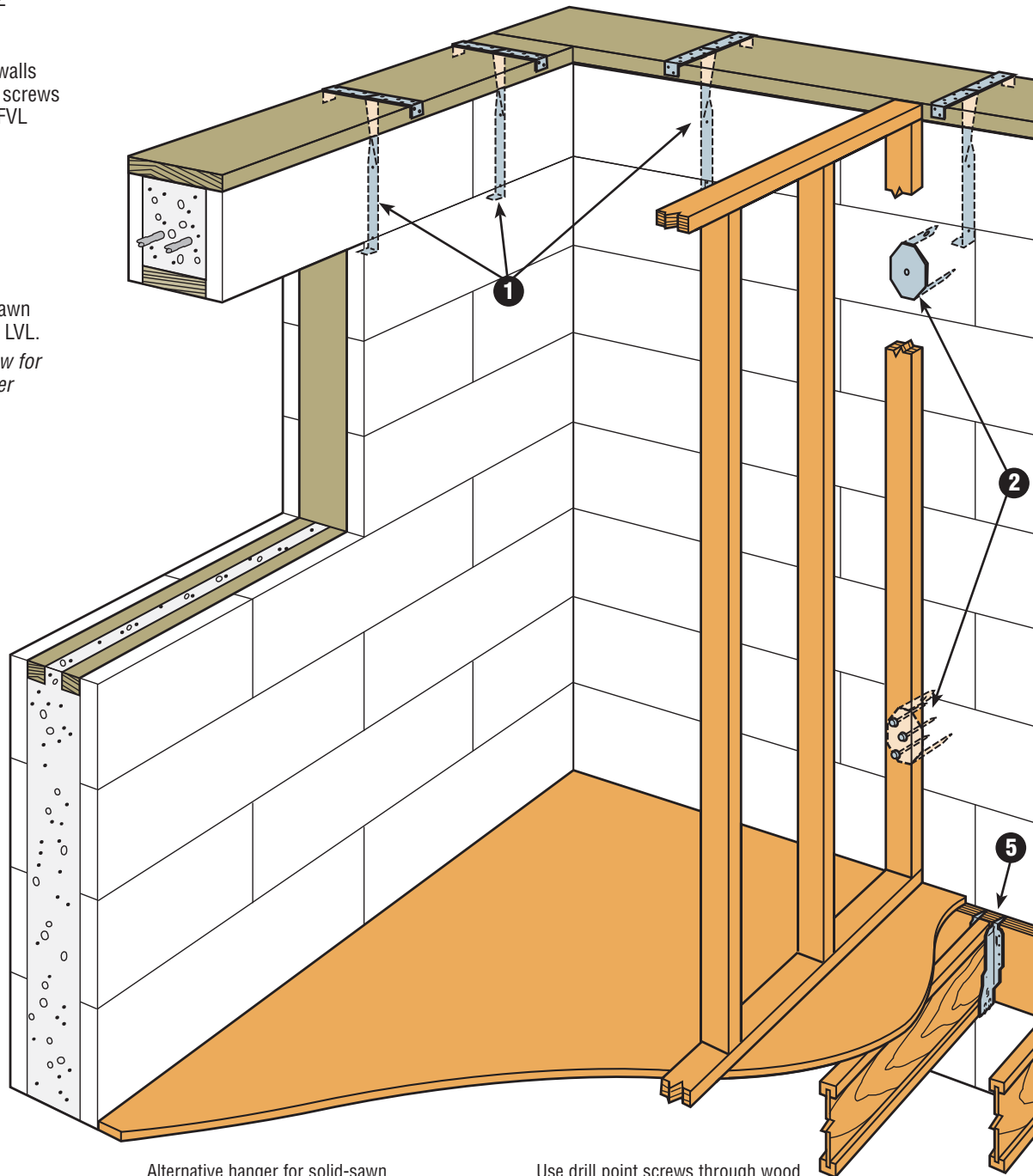

Typical face mount floor truss hangers include, but not limited to, LUS, HUS, HGUS and HHUS. Attachment of second ledger to be designed by others.

Alternative hanger for solid-sawn floor joist using LUS joist hangers.

Use drill point screws through wood cabinets and into the ICFVL connector.

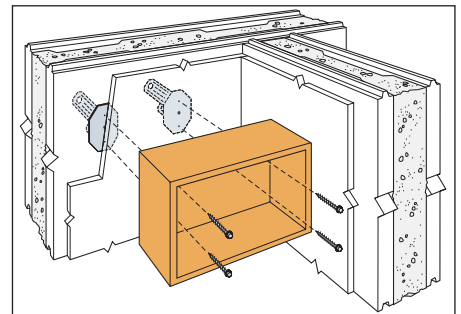
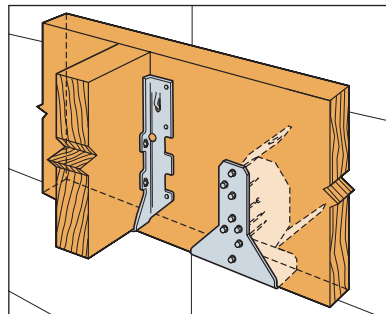
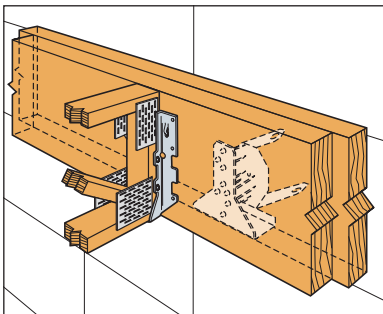

Plate Connections

MAB Anchor Spacing

Model No.	O.C. Spacing to Replace ½" Anchor Bolts 6' O.C.	O.C. Spacing to Replace ¾" Anchor Bolts 6' O.C.	Min. Concrete End Distance	Min. C-C Spacing
	(160)	(160)		
MAB15	2'-9"	1'-11"	6½"	13"
MAB23	2'-9"	1'-11"	12"	24"

1. Place anchors not more than 1' from the end of each sill per code.
2. Spacing is based on parallel to plate load direction only.
3. All grout and concrete min. f_c 2000 psi.
4. Spacing applies to DF, SP and HF 2x sill plates.

Typical MAB23 Installation into ICF

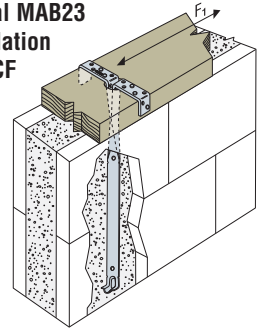

Titen HD® Anchor

The Titen HD® Anchor may be used for sill plate applications. Use bearing plates as required by code. Refer to the appropriate code report, or use Simpson Strong-Tie® Anchor Selector™ software. Download at: www.simpsonanchors.com/software.

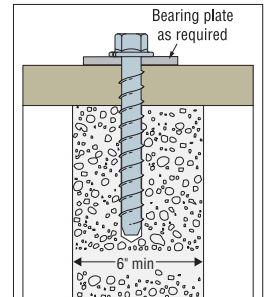

Titen HD® Anchor

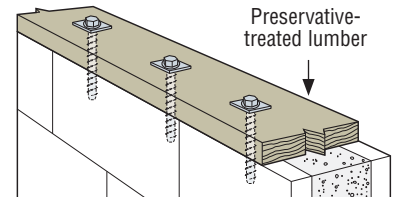

Titen HD installation into ICF

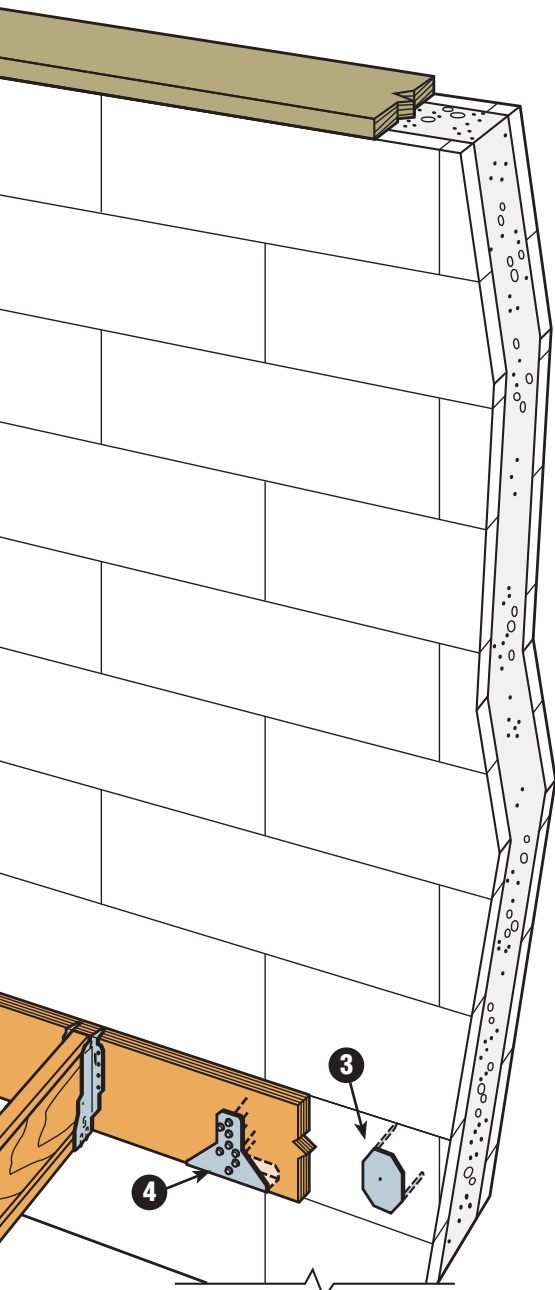

For additional corrosion information, see the current Simpson Strong-Tie® Wood Construction Connectors catalog or www.strongtie.com.

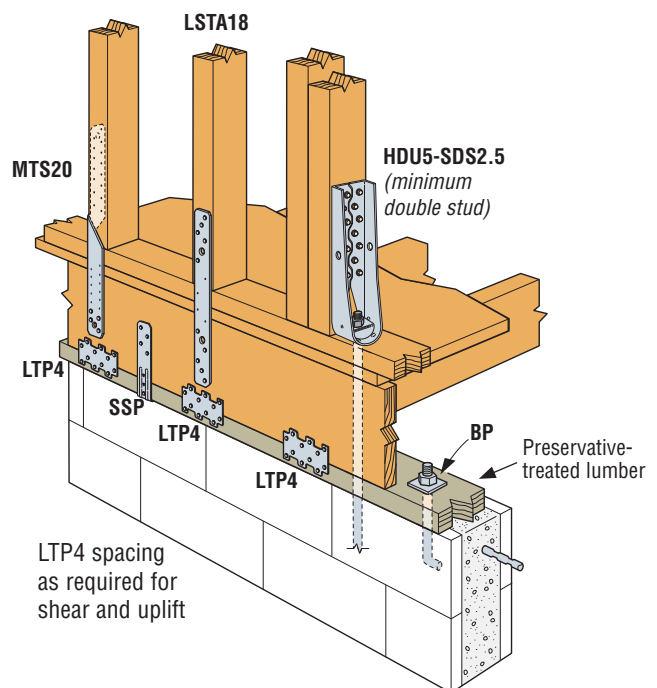

Truss Connections

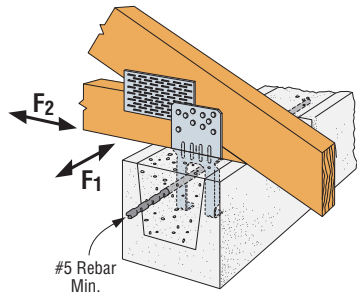

LTA Lateral Truss Anchor, for high uplift and lateral values, eliminates treated plate.

See the current Simpson Strong-Tie® Wood Construction Connectors catalog or www.strongtie.com for additional information on lateral truss anchors.

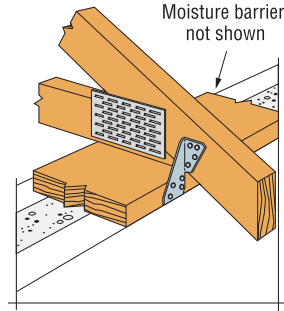

H4 for single plate-to-truss connection

See the current Simpson Strong-Tie® Wood Construction Connectors catalog or www.strongtie.com for additional information on and other models of seismic and hurricane ties.

Model No.	Fasteners	Allowable Loads (160) ¹		
		Uplift	Lateral	
			F ₁	F ₂
LTA2	10-10dx1½	1015	415	735

1. Allowable loads are for SPF/HF species wood. See the current Simpson Strong-Tie® Wood Construction Connectors catalog or www.strongtie.com for additional wood and installation information.

Model No.	Ga	Fasteners			Allowable Loads (160) ¹		
		To Rafter or Truss		To Plates	Uplift	Lateral	
		Single Ply	2 Ply or Greater			F ₁	F ₂
H4	20	4-8dx1½	4-8d	4-8d	235	140	135

1. Allowable loads are for SPF/HF species wood. See the current Simpson Strong-Tie® Wood Construction Connectors catalog or www.strongtie.com for additional wood and installation information.

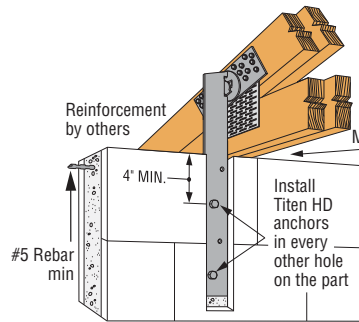

FGTR installation into ICF

See the current Simpson Strong-Tie® Wood Construction Connectors catalog or www.strongtie.com for additional information on face-mount girder tiedowns.

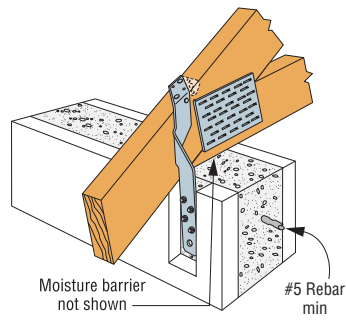

Typical MTSM20 installation into ICF

See the current Simpson Strong-Tie® Wood Construction Connectors catalog or www.strongtie.com for additional information on and other models of twist straps.

Model No.	Fasteners		Allowable Uplift Loads (160) ¹
	To Rafters or Truss	To Concrete	
FGTR	18-SDS ¼"x3"	2-½"x5" Titen HD	3600

1. Allowable loads are for SPF/HF species wood. See the current Simpson Strong-Tie® Wood Construction Connectors catalog or www.strongtie.com for additional wood and installation information.

Model No.	L	Fasteners			Allowable Uplift Loads (160) ¹
		To Rafter or Truss		To Concrete	
		Single Ply	2 Ply or Greater		
MTSM20	20	7-10dx1½	7-10d	4-¼"x1¾" Titen	750

1. Allowable loads are for SPF/HF species wood. See the current Simpson Strong-Tie® Wood Construction Connectors catalog or www.strongtie.com for additional wood and installation information.

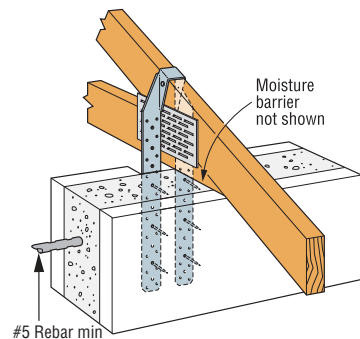

H16S installation into ICF

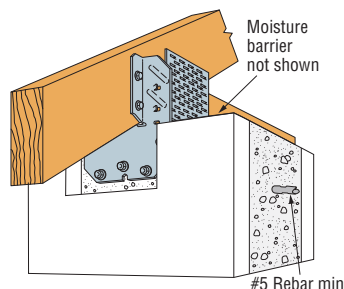

HM9 installation into ICF

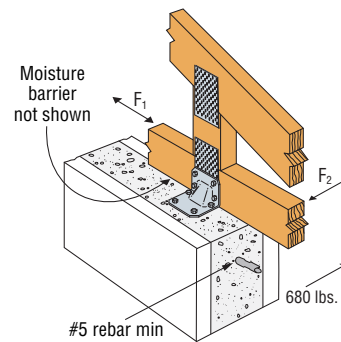

HGAM10 installation into ICF

Model No.	Ga	Fasteners		Allowable Loads ⁴		
		To Rafter or Truss	To Concrete	Uplift	F ₁	F ₂
HM9	18	4-SDS ¼"x1½"	5-¼"x1¾" Titen	595	425	200
HGAM10	14	4-SDS ¼"x1½"	4-¼"x1¾" Titen	610	725	795

1. Loads have been increased 60% for earthquake or wind loading with no further increase allowed. Reduce where other loads govern.
2. Minimum edge distance is 1½" when using Simpson Strong-Tie® Titen® screws.
3. See the current Simpson Strong-Tie® Wood Construction Connectors catalog for additional dimensional, installation and loading information.
4. Allowable loads are for SPF/HF species wood. See the current Simpson Strong-Tie® Wood Construction Connectors catalog or www.strongtie.com for additional wood and installation information.
5. The HM9KT is sold as a 10-pack with the required fasteners. The HGAM10KTA is sold as a 10-pack with the required fasteners.

ICF Connectors

GENERAL NOTES:

1. These products are not intended for use with preservative-treated lumber.
2. Do not splice ledger at ICFVL location.
3. No load duration increase is allowed.
4. Minimum concrete compressive strength (f'_c) is 2500 psi.
5. Use the unity equation when applying vertical and lateral loads simultaneously.
Design Download/Allowable Download + Design Lateral Load/Allowable Lateral Load ≤ 1.0 .

WARNING: Industry studies show that hardened fasteners can experience performance problems in wet environments. Accordingly, use this product in dry, interior applications only.

Wood Ledgers

Allowable Loads (lbs) – ASD	
Vertical	Lateral
1940	1905

1. Use (8) ICF-D3.62 screws (provided).
2. Loads apply to ICFs with foam thickness $2\frac{3}{4}$ " or less. Contact Simpson Strong-Tie for allowable loads on thicker walls.
3. Loads assume a minimum Spruce Pine Fir ledger.
4. Loads may not be increased for short term loading.
5. The ICFVL must be installed no closer than 4" below the top of the wall to achieve the allowable loads shown. For installations where the ICFVL is installed less than 4" from the top of the wall (including flush applications) multiply the allowable loads by 0.94.

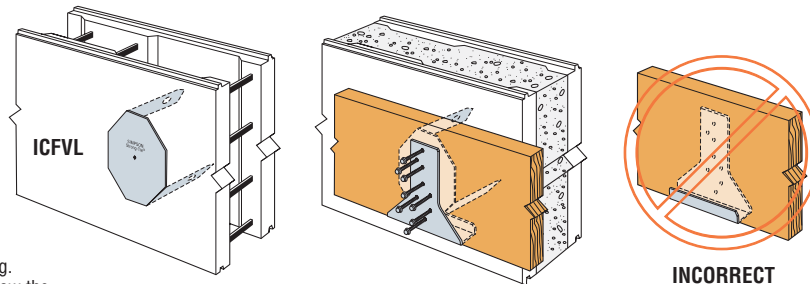

Typical Wood Ledger Installation with ICFVL and ICFVL-W
(ICFVL-CW for LVL ledger similar)

ICFVL Spacing to Replace Anchor Bolts							
$\frac{1}{2}$ " Diameter Bolts				$\frac{5}{8}$ " Diameter Bolts			
12" o.c.	24" o.c.	36" o.c.	48" o.c.	12" o.c.	24" o.c.	36" o.c.	48" o.c.
48"	48"	48"	48"	48"	48"	48"	48"
(2) $\frac{3}{8}$ " Diameter Bolts				$\frac{3}{4}$ " Diameter Bolts			
12" o.c.	24" o.c.	36" o.c.	48" o.c.	12" o.c.	24" o.c.	36" o.c.	48" o.c.
24"	48"	48"	48"	42"	48"	48"	48"

1. This table addresses vertical load applications only.
2. The Designer may specify different spacing based on the load requirements.
3. Spacings are based on perpendicular to grain capacity of bolt in Spruce-Pine Fir wood ledger compared to tested value of ICFVL with a maximum allowable spacing of 48".
4. Connector spacing requirements are based on a $C_D = 1.00$ load duration. Contact Simpson Strong-Tie for alternate load durations.
5. Bolt design values are based on 2005 NDS Table 11E for a dowel bearing strength of $F_e = 7500$ psi in concrete with a minimum $f'_c = 2500$ psi and a 6" anchor embedment with a bolt bending yield strength of $F_{yb} = 45000$ psi.

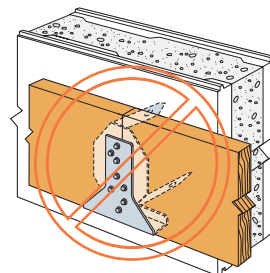
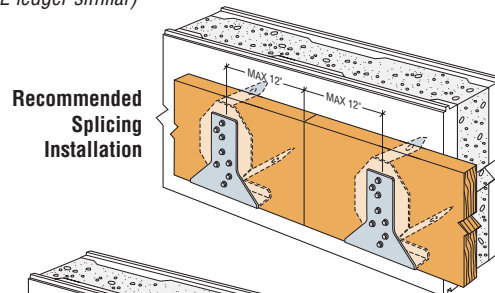

Steel Ledgers

Allowable Loads (lbs) – ASD	
Vertical	Lateral
1660	1525

1. Use four $\frac{1}{4}$ -14x $\frac{3}{4}$ ", #3 drill point screws (not provided).
2. Loads apply to ICFs with wall thickness $2\frac{3}{4}$ " or less. Contact Simpson Strong-Tie for allowable loads on thicker walls.
3. The ICFVL must be installed no closer than 4" below the top of the wall to achieve the allowable loads shown. For installations where the ICFVL is installed less than 4" from the top of the wall (including flush applications) multiply the allowable loads by 0.94.

Ledger Thickness (mils)	ICFVL Spacing to Replace Anchor Bolts			
	$\frac{1}{2}$ " Diameter Bolts		$\frac{5}{8}$ " Diameter Bolts	
	12" o.c.	24" o.c.	12" o.c.	24" o.c.
68 mils (0.068")	11"	22"	9"	18"
54 mils (0.054")	15"	30"	12"	24"

1. This table addresses vertical load applications only.
2. For steel ledgers, the 68 mil ledger spacing is closer than the 54 mil ledger because the calculated load of a bolt is higher in a thicker piece of steel.
3. Steel ledger values are based on steel. $F_u = 60$ ksi.

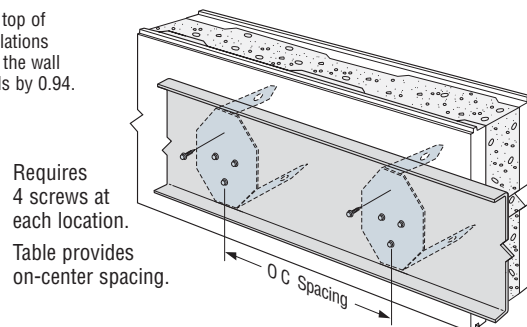

Typical Steel Ledger Installation with ICFVL
(Minimum 16 gauge, 54 mil steel ledger)

ICF Connectors

The following spacing tables are an alternative to the ICFVL spacing to replace anchor bolts tables or allowable loads on page 5. They give the spacing of the ICFVL Ledger Connectors based on the allowable vertical load of the connector, the load on the floor and the span of the joists. The Designer must determine the design load, the ledger design and joist design. This table is useful if the Designer already has loads and spans, but not necessarily anchor bolt spacing.

Uniform Loads		ICFVL Spacing for SPF Wood Ledger (in)									
Dead Load (psf)	Live Load (psf)	Joist Span (ft)									
		10	12	14	16	18	20	22	24	26	28
10	40	48	48	48	48	48	47	42	39	36	33
15	40	48	48	48	48	47	42	38	35	33	30
20	40	48	48	48	48	43	39	35	32	30	28
10	60	48	48	48	42	37	33	30	28	26	24
20	60	48	48	42	36	32	29	26	24	22	21
30	60	48	43	37	32	29	26	24	22	20	18
40	60	47	39	33	29	26	23	21	19	18	17
10	100	42	35	30	26	24	21	19	18	16	15
20	100	39	32	28	24	22	19	18	16	15	14

See notes below.

Uniform Loads		ICFVL Spacing for Steel Ledger (in) – 54 mils									
Dead Load (psf)	Live Load (psf)	Joist Span (ft)									
		10	12	14	16	18	20	22	24	26	28
10	40	48	48	48	48	44	40	36	33	31	28
15	40	48	48	48	45	40	36	33	30	28	26
20	40	48	48	47	42	37	33	30	28	26	24
10	60	48	47	41	36	32	28	26	24	22	20
20	60	48	42	36	31	28	25	23	21	19	18
30	60	44	37	32	28	25	22	20	18	17	16
40	60	40	33	28	25	22	20	18	17	15	14
10	100	36	30	26	23	20	18	16	15	14	13
20	100	33	28	24	21	18	17	15	14	13	12

1. This table addresses vertical load applications only.
2. Values shown are maximum spacing distances (in) based on simple span, uniformly loaded conditions and do not consider concentrated loads.
3. Joist and ledger are to be designed by others.
4. Allowable loads are based on testing, with no further increases allowed.
5. Tables above address vertical loads only. If connection is designed to resist lateral loads, spacing will decrease. Contact Simpson Strong-Tie for current information.

Alternative Retrofit Solution for Direct Attachment of Joist to Wall

The HU and HUC hangers are heavy duty face mount joist hangers made from 14-gauge galvanized steel. These hangers can be directly attached to concrete wall using ¼"x1¾" Simpson Strong-Tie® Titen® hex head screws. See www.strongtie.com for more information on installation and use.

Simpson Strong-Tie offers many retrofit products for attaching wood or steel framing members to concrete. For expanded details contact us at (800) 999-5099 and request the current *Anchoring and Fastening Systems for Concrete and Masonry* catalog, or visit the Simpson Strong-Tie Anchor Systems® website at www.simpsonanchors.com.

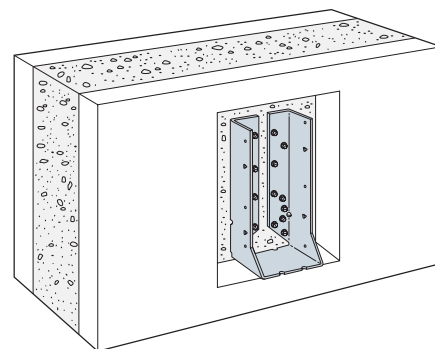

HUC410 Installed on face of concrete in ICF

This flier is effective until **January 31, 2013**, and reflects information available as of **September 1, 2010**. This information is updated periodically and should not be relied upon after **January 31, 2013**; contact Simpson Strong-Tie for current information and limited warranty or see www.strongtie.com.

© 2010 Simpson Strong-Tie Company Inc. • P.O. Box 10789, Pleasanton, CA 94588

F-ICFVL10 9/10 exp. 1/13

6/13

800-999-5099
www.strongtie.com