

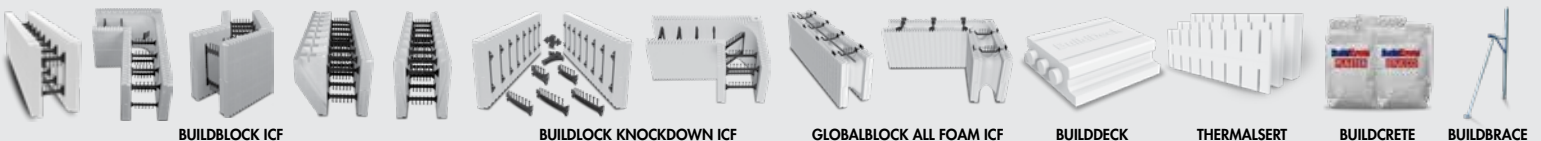

# BUILDBLOCK BUILDING SYSTEMS BUILDBRACE ICF BRACING & ALIGNMENT SYSTEM PRODUCT MANUAL



BUILDBLOCK ICF

BUILDLOCK KNOCKDOWN ICF

GLOBALBLOCK ALL FOAM ICF

BUILDDECK

THERMALCERT

BUILDCRETE

BUILDBRACE



# BUILDBRACE ICF BRACING & ALIGNMENT SYSTEM PRODUCT MANUAL

## Table of Contents

---

<b>THE BUILDBRACE ICF BRACING AND ALIGNMENT SYSTEM .....</b>	<b>1</b>
Product Overview .....	1
<i>BuildBrace Products</i> .....	1
Build1 - All-In-One Folding ICF Alignment System .....	2
Build3 - 3-Piece ICF Alignment System.....	2
Transport & Storage Crates.....	3
<i>Storage Crate Customization</i> .....	3
24-Foot Adapter Kit.....	3
BuildBrace Features.....	3
<i>Alignment Control at Platform Level</i> .....	3
<i>Enclosed Adjustment</i> .....	4
<i>3 Way Anchor Foot - Screw-Rebar-Stake</i> .....	4
<i>Sizes</i> .....	4
<i>Safety Rail Post Mount</i> .....	4
<i>Light Weight</i> .....	4
<i>Heavy Duty</i> .....	4
BuildBrace Components.....	4
<i>Strongback</i> .....	4
<i>Outrigger</i> .....	4
<i>Platform Bracket</i> .....	4
Performance and Specific Requirements.....	4
Bracing Setup & Usage .....	5
Usage Notes .....	5
Stacking and Installing bracing .....	6
Wind Resistance .....	7
Bracing Spacing and Other Considerations .....	7
Handling and Maintenance .....	7
Inspection.....	7
BuildBrace Engineering .....	8
<i>Design Loads</i> .....	8
<i>Constraints</i> .....	8
<i>Tall Wall Engineering</i> .....	11
<i>CAD Details</i> .....	25



**BUILDBRACE PRODUCT MANUAL**

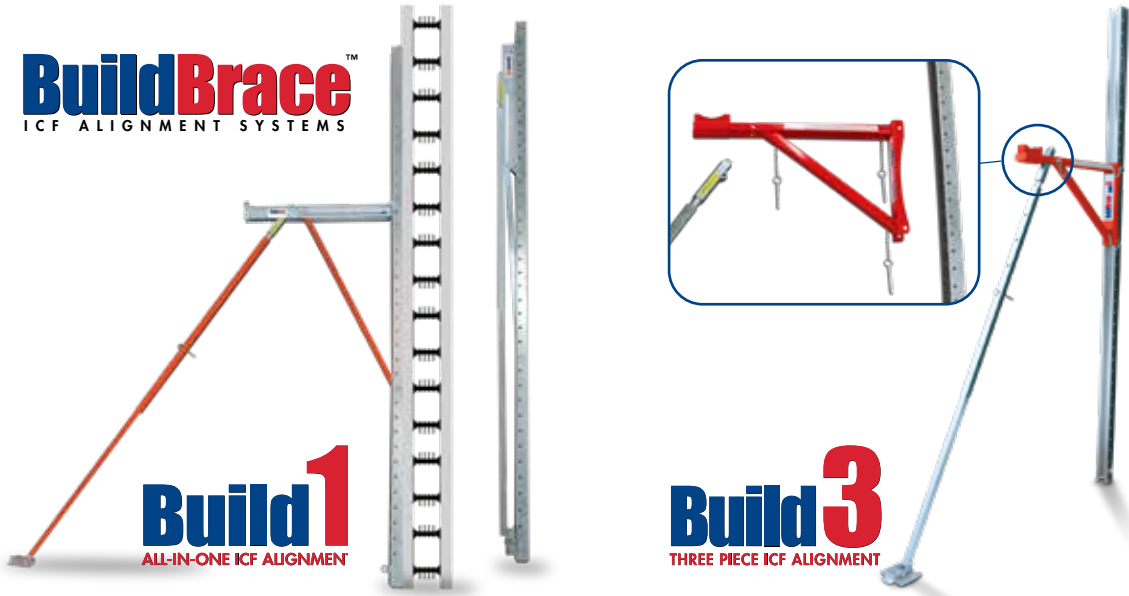

# THE BUILDBRACE ICF BRACING AND ALIGNMENT SYSTEM

## PRODUCT OVERVIEW

The BuildBrace ICF Bracing and Alignment System manufactured by Plumwall is a comprehensive system to brace and align ICF walls. The system provides support for contractors during stacking and pouring of the walls. It also provides a way to plumb and straighten walls during and immediately after the pour.

Utilizing BuildBrace allows a contractor to build ICF walls fast and straight, while ensuring a safe work environment and providing a professional job site appearance.

BuildBrace is a leading innovator in the field of high quality, easy-to-use ICF bracing systems. ICF braces are engineered with an exclusive one-person alignment control at platform

level and are durably built to support ICF walls of any thickness up to 24-feet in height.

The BuildBrace system is available in two configurations: The Build1 all-in-one and Build3 three-piece system. The systems are nearly identical once assembled and provide the same level of safety and performance.

BuildBrace provides a superior system to ensure walls are straight and plumb in the safest working environment.

Available transportation and storage crates hold 24 BuildBrace ICF braces, are stackable and available in a selection of standard or custom colors.

BUILDBRACE PRODUCTS
8' Build1 All-In-One Brace
9' Build1 All-In-One Brace
10' Build1 All-In-One Brace
12' Build1 All-in-One Brace
8' Build3 Brace
9' Build3 Brace
10' Build3 Brace
12' Build3 Brace
14' Build3 using 1 10' Brace and 4' adapter kit (includes 1 outrigger extension )
14' All-In-One using 1 10' Brace and 4' adapter kit (1 outrigger extension and Build 3 Platform)
16' All in One using 1 12ft Brace and 4' adapter kit (includes 1 outrigger extension)

BUILDBRACE PRODUCTS
24' Using 1 10' All in One 1 10ft Build 3 and 4' adapter kit (includes 3 outrigger extensions)
24' Build 3 Using 2 10' Braces and 4' adapter kit (includes 3 outrigger extensions)
4' Adapter Kit for 14' (includes 1 outrigger extension) No Platform included
4' Adapter Kit for 16' (includes 2 outrigger extensions) No Platform included
4' Adapter Kit for 24' (includes 3 outrigger extensions) No Platform included
Build 3 Platform
Standard 10' Transport Crate
Standard 12' Transport Crate (Build1 Only)

## BUILDBRACE PRODUCT MANUAL

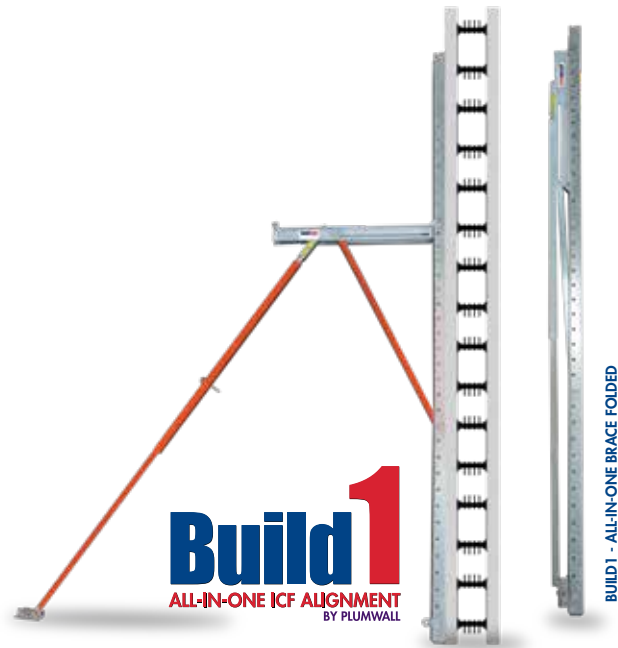

### BUILD1 - ALL-IN-ONE FOLDING ICF ALIGNMENT SYSTEM

The Build1 system folds together in one unit for storage and transport. Build1 is designed for quick setup, easy alignment at platform level, storage and transport, delivering unparalleled productivity and efficiency.

BuildBrace Build1 is always ready for use. No missing parts to locate, just unfold and begin working.

Build1 Braces are easy to set up, with no assembly required. Simply unfold the brace, position it and fasten it to the walls and floor. The bracing should be attached through the slots in the strongback using a pan head or duplex screw.

The foot bracket should be solidly anchored to the floor or soil with appropriate fasteners, or pins. Each brace should be fully inspected following installation, to ensure it is firmly affixed to the floor and the wall.

Walkboards should be installed and safety railing added to conform to applicable local safety standards. All safety equipment should be inspected regularly for damage and repaired or replaced as necessary.

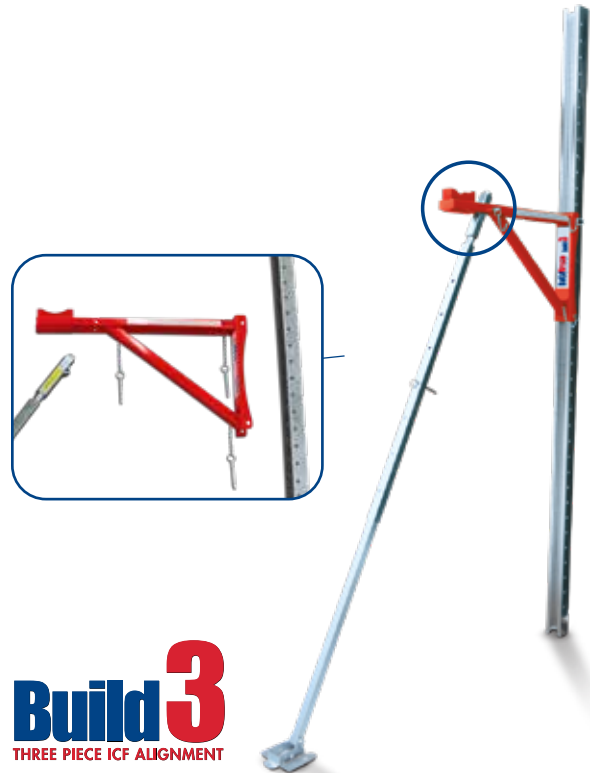

### BUILD3 - 3-PIECE ICF ALIGNMENT SYSTEM

Build3 combines BuildBrace's exclusive alignment control at platform level with the simplicity and durability of a conventional three-piece system. The pin-on platform bracket mounts to the 14-gauge galvanized steel strongback with the outrigger connecting to the platform bracket.

This system is also easily transported to the job site and is easy to carry. The versatile nature of the 3-piece system allows missing or damaged components to be easily replaced.

BuildBrace Build3 is assembled by attaching the strongback to the ICF forms, and then installing the triangular shaped angle bracket and the extension leg with the supplied pins.

The foot bracket should be solidly anchored to the floor or soil with appropriate fasteners, or pins. Each brace should be fully inspected following installation, to ensure it is firmly affixed to the floor and the wall.

Walkboards should be installed and safety railing added to conform to applicable local safety standards. All safety equipment should be inspected regularly for damage and repaired or replaced as necessary.

## BUILDBRACE PRODUCT MANUAL



### TRANSPORT & STORAGE CRATES

From job site to job site or floor to floor, BuildBrace Storage Crates provide quick and safe transport of your braces. Crates are available for both Build1 and Build3 models.

- Holds 24 Braces
- Lifting Lugs
- Durable Powder Coated Finish
- Stackable
- Forklift Accessible from All Sides
- Custom End Plates and Color Options Available



BuildBlock branded carrier shown. Custom colors or branding available at an additional charge.

### STORAGE CRATE CUSTOMIZATION

Customize the appearance of your brace crates. Pick from a selection of colors or ask us about matching your company colors for an additional charge.

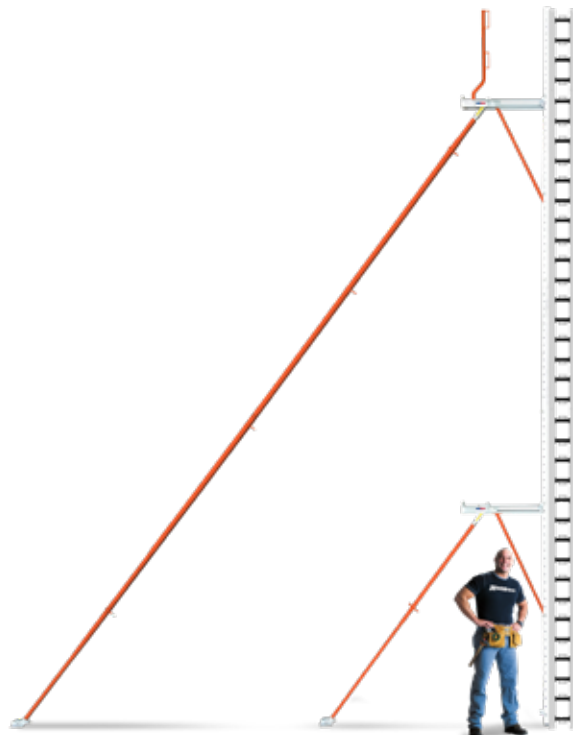

### 24-FOOT ADAPTER KIT

Take ICF to the next level with the BuildBrace Adapter Kit giving you 24-feet in perfect alignment. By integrating flush with both the Build1 and Build3 bracing systems, the Adapter Kit is a 4-foot strongback extension that connects two 10-foot braces together.

This allows you to build and align walls at 10-feet, 14-feet and 24-feet. The Adapter Kit's extended outrigger holds sturdy with double-walled tubing that is easy to assemble.

### BUILDBRACE FEATURES

#### ALIGNMENT CONTROL AT PLATFORM LEVEL

One person, one drill. That's all it takes to adjust the alignment on a BuildBrace ICF brace. Designed for single person use, you can measure and make adjustments without leaving the platform.

This revolutionary alignment control is designed to minimize setup time and maximize worker efficiency.



BuildBrace adjustment at platform level using cordless drill.

## BUILDBRACE PRODUCT MANUAL

	<p><b>ENCLOSED ADJUSTMENT</b></p> <p>Enclosed unit is protected from concrete spillage and mud.</p>
	<p><b>3 WAY ANCHOR FOOT - SCREW-REBAR-STAKE</b></p> <p>Whether aligning the basement foundation or second story, the brace holds firm with anchor holes for rebar, wooden stakes or screws.</p>
<b>8'-12'</b>	<p><b>SIZES</b></p> <p>BuildBrace ICF Braces are available in 8', 9', 10' or 12' strongback heights.</p>
	<p><b>SAFETY RAIL POST MOUNT</b></p> <p>Integrated into the platform bracket is a 2" x 6" mount for safety rail posts.</p>
	<p><b>LIGHT WEIGHT</b></p> <p>BuildBrace braces are easy for one person to carry and setup.</p>
	<p><b>HEAVY DUTY</b></p> <p>All BuildBrace strongbacks are built with 14-gauge, galvanized steel.</p>

### BUILDBRACE COMPONENTS

Careful consideration has been given to the variety of applications that job site conditions and wall forming create to develop a product well suited for the intended use.

The basic system is represented by the following fundamental components:

#### STRONGBACK

The vertical component of the system is a galvanized steel channel intended to be secured to the footing or slab at the base of the wall and to the wall forms through the provided 1 1/2" x 3/16" slots with two screws every course. Use #10 screws to fasten the strongback to the ICF form. Holes drilled 3" o.c. through the sides of the strongback provide locations for mounting the Platform bracket and outrigger using the supplied pins.

#### OUTRIGGER

The diagonal component of the system has 6 fixed adjustment positions. The outrigger can be placed at different angles, within the engineered standards within this document, to accommodate irregular excavation elevations. The enclosed adjustment system can be used for fine adjustments, and is accessible from the platform.

#### PLATFORM BRACKET

The platform bracket provides secure attachment of the outrigger to the strongback. The platform bracket is designed to accept two 2x10 scaffold planks and a 1-inch toeboard.

Secure the overlapping planks together with screws. An integral 2x6 slot can be used to add a vertical support for a hand rail. Place handrails to the inside of the vertical support.



BuildBrace Build1 erected and staked.

### PERFORMANCE AND SPECIFIC REQUIREMENTS

BuildBrace is designed for supporting walls in winds up to 60kmph (37 mph). The platform should be unoccupied at wind speeds above 40kmph (25mph). Any use outside of this range is at the contractors risk.

This manual provides minimum requirements, and additional federal, state, and local codes may apply. The contractor is responsible for researching and meeting these codes.

Spacing of the bracing product should be determined by the installing contractor in accordance with federal, state and local codes for wind bracing and scaffold. The maximum spacing for each BuildBrace product is not to exceed 6 feet.

Scaffold planking and handrail materials should be:

- American – Number 1 Southern Pine or Douglas Fir.
- Approved laminated structural or manufactured planks and stages are recommended.



## BUILDBRACE PRODUCT MANUAL

Contractor is responsible for meeting all applicable codes for anchoring the system, as well as ensuring that all fasteners provide the performance required to meet those standards.

BuildBrace is designed to accommodate a platform load of 2.4KPa (50PSF) or a point load of 2.2KN (500LBS) only.

### RELEVANT CODES AND STANDARDS

The user is responsible to review and apply the requirements of federal, state and local regulations for wind bracing and scaffolding as defined by the above code agencies. The BuildBrace is designed to be in compliance with all applicable Ontario Occupational Health and Safety Act regulations.

This system has been tested and complies with:

1. CAN/CSA-S269.1, Falsework for Construction Purposes
2. CAN/CSA-S269.2-M87, Access Scaffolding for Construction Purposes
3. CAN/CSA-S269.3-M92, Concrete Formwork CSA A371-04
4. Masonry Construction for Buildings National Building Code of Canada
5. 2010 Structural Commentaries (Part 4 of Division B), NBCC 2010

These standards could be compared against others if required by another agency. This system is also engineered to meet the standards set forth in the accompanying engineering documentation.

### BRACING SETUP & USAGE

Build1 Braces are easy to set up, with no assembly required. Simply unfold the brace, position it and fasten it to the walls and floor. The bracing should be attached through the slots in the strongback using a pan head or duplex screw.

BuildBrace Build3 is assembled by attaching the strongback to the ICF forms, and then installing the triangular shaped angle bracket and the extension leg with the supplied pins.

The foot bracket should be solidly anchored to the floor or soil with appropriate fasteners, or pins. Each brace should be fully inspected following installation, to ensure it is firmly affixed to the floor and the wall.

Walkboards should be installed and safety railing added to conform to applicable local safety standards. All safety equipment should be inspected regularly for damage and repaired or replaced as necessary.

### USAGE NOTES

- Do not exceed the duty rating of this unit.
- The maximum safe weight load for each unit is 500 pounds. Over loading could cause serious injury or death.
- Place the unit on a firm surface where footing is solid, rigid and capable of carrying the maximum intended load without slipping.

- Do not place the unit on snow, ice, loose gravel, mud, leaves or other slippery surfaces.
- Be sure the vertical strongback channel, foot and base clips are properly secured to avoid slipping.
- Do not place boxes, ladders or other scaffolding on top of the plank to gain additional height.
- This unit IS NOT to be used independent of a rated plank or stage.
- Be sure all locking devices are secure.
- Do not use the unit beyond a plank height of 20 feet off the ground or floor.
- Be sure the plank or stage is supported a minimum of 12 to 18 inches on each end.
- The recommended spacing for the unit is not to exceed 6 feet.
- Never set the units in front of unlocked doors or in other locations where the units could be bumped or kicked.
- Barricades must be used where necessary.
- Do not apply side loads to the unit or plank.
- Never pull or push anything while working on the units.
- Do not use the unit without an appropriately rated scaffold plank or stage.
- **DANGER!** Steel braces conduct electricity! Keep unit away from uninsulated electrical circuits and wires. Use extreme caution when working near electrical wires. Failure to comply may result in serious injury or death.
- Maximum scaffold height is 24 feet.
- SECURELY ENGAGE ALL PINS BEFORE CLIMBING.
- Be sure to use fall restraint devices as prescribed by local, state and federal authorities.
- Failure to comply with all local, state and federal requirements may result in serious injury or death.
- Never drop or apply an impact load to the unit.
- Do not use the unit if you are not in good physical condition or are under the influence of any substance (including prescription medicine) that may impair your ability to use the unit properly and safely.
- Do not leave the unit set up when unattended.
- Do not use in high winds.
- Keep your body center in the work platform.
- Do not overreach.
- Never hoist anything from the scaffold plank.
- Do not bounce or run on the scaffold plank.
- Keep the unit clean and free of all foreign material. Do not store any material on the unit.
- The units should be properly supported and secured during transport. Always store in a clean, dry place.
- **WARNING:** All accessories must be installed in accordance with the manufacturers recommended procedure.

## BUILDBRACE PRODUCT MANUAL



BuildBrace Build1 ICF Bracing.

### STACKING AND INSTALLING BRACING

1. Snap all lines for locations of forms, or set string lines for reference.
2. Stage all materials and bracing inside the wall location, leaving about 6ft for workspace minimum inside the perimeter.
3. Stack 4ft (3 courses) of ICFs before installing the Bracing.
4. Locate the positions for the braces, and center them on the form ties.
5. Stand the strongback in position and secure it to the footing through 2 of the four attachment holes at the base of the channel.
6. Using two #10 coarse thread, pan head, wood screws every of block, secure the strongback to the ICF forms by screwing into the form ties through the slotted holes in the back of the strongback. The screws should be located at the top of the slot and tightened enough to hold the strongback to the forms and prevent the forms from floating upwards, but allow the forms to settle as they are filled with concrete.
7. Attach the Platform Bracket to the strongback using the supplied pins, and then attach the outrigger to the platform bracket. Refer to the BuildBrace drawing in the back of this user manual. Hold a level held parallel to the strongback at eye-level and bring the strongback to within 1.5 degrees of plumb with the wall leaning in towards the brace. Adjust the length of the outrigger, first at the fixed adjustment locations, then with the enclosed adjustment, and anchor the hinged foot brace.
8. Complete bracing set up prior to installing planking. Inspect each brace to ensure no steps were missed.
9. As additional courses are stacked, affix the blocks, every course, to the strongback with 2 screws. Screwing into the BB hardpoint will yield the most strength. Starting in 2015, BuildBrace strongbacks will have additional slots to make it easier to hit the BB hardpoints.
10. OSHA requires scaffolding; handrails and toe board if the workers feet are 6' or more off the ground. When the wall is fully stacked, reinspect all braces and planks to ensure they are properly installed and attached.
11. An initial tilt of the wall toward the brace (1/4" or less) will allow the wall to be pushed to plumb, using the full bearing of the strongback, rather than pulled, using the tensile strength of the screws. The wall should be adjusted to plumb continuously before concrete in the wall sets.
12. Once the wall has been poured, the final adjustment to plumb can be completed with the enclosed adjustment system and accessibility from the work platform.
13. Follow ACI and OSHA guidelines for brace removal timeframes.

## BUILDBRACE PRODUCT MANUAL

### WIND RESISTANCE

The BuildBrace is designed and engineered to resist wind loads from winds of up to 60kmph (37mph). Normal construction limits the potential wind resistance to that which foundation resistance will allow.

When used to provide wind bracing where the strut is staked to soil, the brace unit shall be installed on two sides of the wall. The mass of normal strip footings available to resist wind uplift limits safe occupancy of the scaffold to concurrent winds of 60kmph (37mph).

Where scaffold members are anchored to soil, at wind speeds in excess of 40 kmph (25mph) the scaffold should be evacuated by all personnel.

Where the competent founding materials are available to develop anchor loads, the brace may be installed on one side only.

### BRACING SPACING AND OTHER CONSIDERATIONS

- Determine the number of braces required, based on wall length, corners and openings.
- Maximum spacing of the brace is 6 feet.
- Braces should be placed each direction at corners, either inside or outside, and at each side of an opening. Bracing spacing should be maintained for larger openings, placing braces as needed within the opening distance to allow for straightening and alignment of the header.
- Braces should be distributed evenly along the wall, with additional braces for corners and openings interspersed.
- When bracing to the inside of a corner, the first brace should be set at normal height, and the second brace placed lower, to clear the first.
- For longer and taller walls, bracing on both sides of the wall is recommended.
- Wood "Kickers" may be required at the corner to support the walk boards. A board may also be screwed horizontally to the forms above the kickers for more support.

### HANDLING AND MAINTENANCE

BuildBrace alignment systems are made of the finest materials and coatings. The bracing components should be thoroughly cleaned of any concrete overspill with a small putty knife and a sponge with water, as soon as the pour is completed, for ease of cleaning. If the concrete hardens on the braces, it may require more aggressive cleaning methods. Do not use acid water to clean the bracing.

Reasonable handling and maintenance will result in years of dependable service.

The enclosed adjustment system should not require excessive cleaning or maintenance. It is recommended to grease the adjuster thread as required, typically once per year.

**WARNING! FAILURE TO READ AND FOLLOW ALL INSTRUCTIONS MAY RESULT IN SERIOUS INJURY OR DEATH.**

### INSPECTION

Inspect each unit for damage when setting up, and when taking down the bracing. Any units found to be damaged should be set aside and marked, for repair or replacement.

## BUILDBRACE PRODUCT MANUAL

## BUILDBRACE ENGINEERING

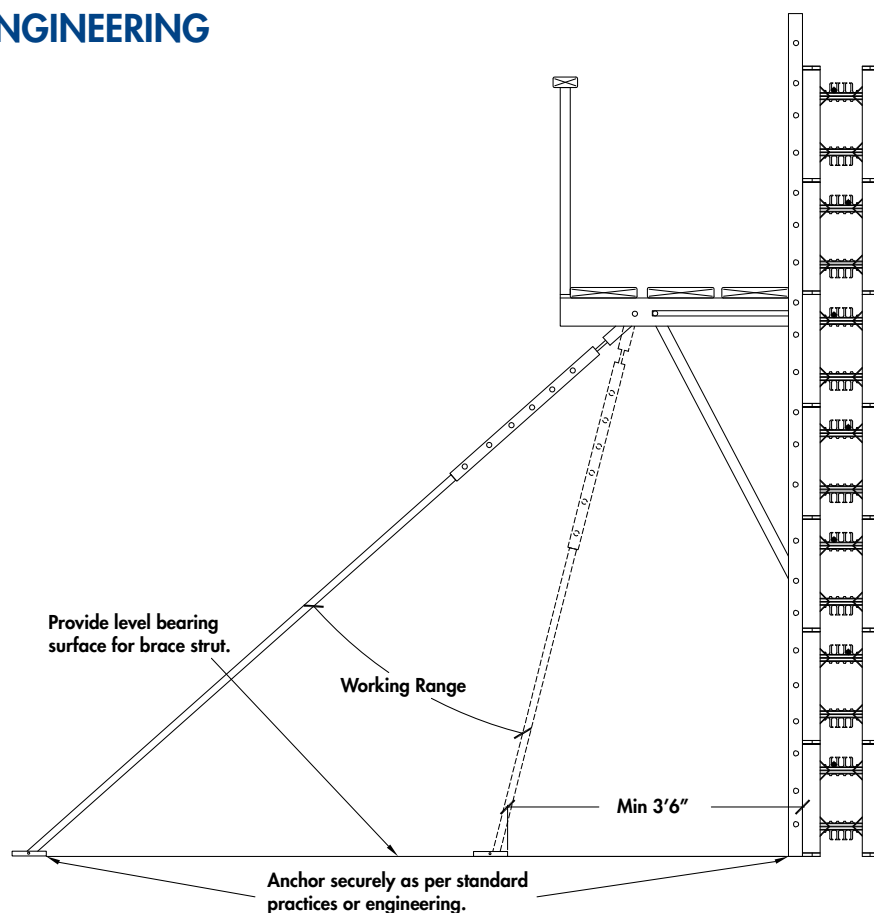

Scaffold platform conforms to Ontario Health and Safety Act requirements for a scaffold and work platform. This is not intended to be used to support masonry.

**DESIGN LOADS**

Platform Live load = 2.4KPa (50PSF)

Horizontal Live Load = 0.50KPa (10PSF)

**CONSTRAINTS**

1. To be used in conjunction with Insulated Concrete Forms (ICF) up to 24 feet when using the 24-foot adapter.
2. Vertical uprights are not to be coupled to achieve greater heights unless using the 24-foot adapter.
3. Any cutting, welding, bolting, and or adjustment of brace's design is not recommended, and will void any warranty and/or liability by PLUMWALL™ in relation to any further use of the product.
4. Vertical upright and brace assembly must be secured to ICF wall with 2 #10 x 38mm (3/16" x 1-1/2") screws and slotted bracket on every ICF course.
5. Braces should be no more than 1820mm (6'-0") apart and doubled up in corners.
6. Scaffolding should be constructed to conform to Ontario Occupational Health and Safety Act regulations.
7. Brace and scaffold is designed to accommodate a platform load of 2.4KPa (50PSF) or a point load of 2.2KN (500LBS) only.
8. Brace should not be used when wind velocities exceed 60KPH (37MPH).
9. Maximum brace extension to be 9'6" and the base anchorage shall be a minimum of 3'6" from the face of the vertical upright.
10. The anchorage of the Plumb Wall brace is site specific and must be verified by an engineer.
11. The base anchorage shall be level with the base of the vertical upright.
12. All bracing and ICF connectors should be inspected by personnel trained in ICF construction before erection and prior to concrete pour.
13. Bracing that has been damaged in any way should be painted a bright cautionary red and set aside for repair or disposal.
14. Any bracing that has been damaged during shipping should be immediately returned for replacement.
15. Failure to comply with the above noted installation and design instructions immediately absolves PLUMWALL™ and BuildBlock Building Systems from any and all liability claims.

BUILDBRACE PRODUCT MANUAL

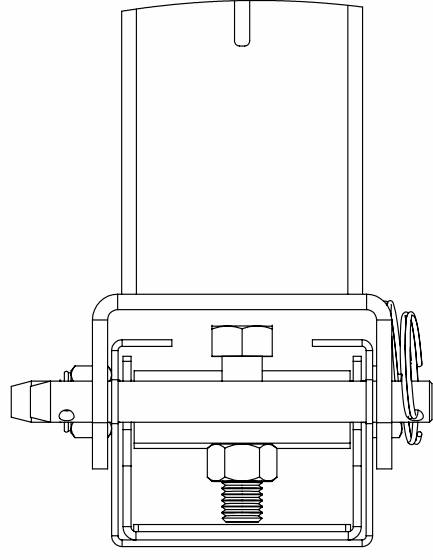
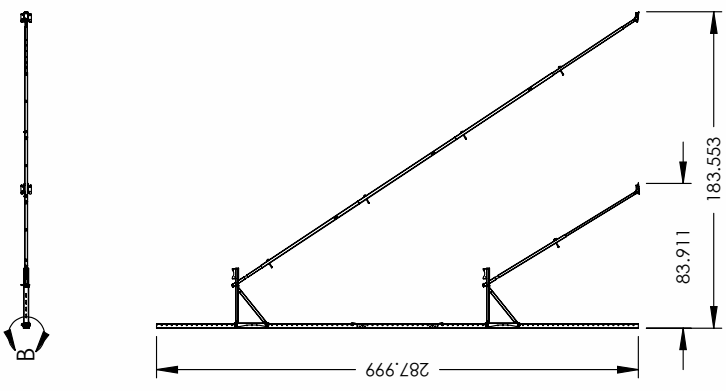
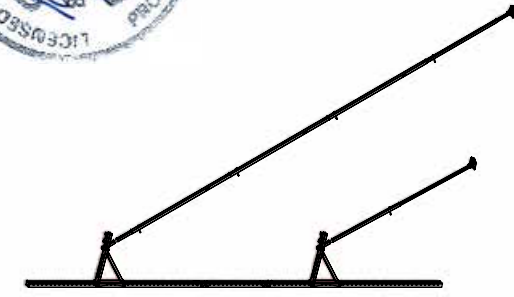

DETAIL B  
SCALE 1 : 2

**NOTES:**

- Approved for use as ICF forming brace with the following limitations:
- Braces to have 6' spacing Maximum
- No more than 25 psf vertical loading on platform in combination with 500 lb of worker load per brace
- Platform to be unoccupied by personal at wind speeds greater than 40 Kph
- Prior to any use, all components to be inspected for corrosion, deformation, or other damage
- Upon erection of tall wall brace, any braced component where long brace has a sag greater than 6" shall not be used
- Full details of testing and compliance with required codes can be found in Breukelman Design Inc. report: "Plumwall Tall Brace Test Report"

DO NOT SCALE DRAWING	MATERIAL: As Per Part	FINISH:	PART NO. PLMBRACE-A210	REV DATE: 30/03/2012
UNLESS OTHERWISE SPECIFIED DIMENSIONS ARE IN INCHES	WEIGHT LBS: - 213.00	SCALE: 1:96	TITLE: 24FT Brace	AUTHOR: Mahlon M.
Sheet Name: <b>Sheet1</b>	PROJECT: -	SHEET 1 OF 2		

**Plumwall**  
Ontario Canada  
(888) 928-6676

## BUILDBRACE PRODUCT MANUAL

**D. G. Biddle & Associates Limited**

consulting engineers and planners

96 KING ST. E., OSHAWA, ONTARIO L1H 1B6 PHONE (905) 576-8500 FAX (905) 576-9730  
e-mail: dgiddle@idirect.com

June 26, 2003

**Excalibur**940 Brock Rd.  
Pickering, ON.  
L1W 2A1

Attn: Tom Summerville, President

**Re: Structural Review of the PLUMB Wall™ ICF brace.****Our File: 103532**

Dear Sir,

Our office has analyzed the PLUMB Wall™ brace to determine its adequacy to be used for insulated concrete wall form support in accordance with the provisions of the Ontario Occupational Health and Safety Act.

Our analysis considered the PLUMB Wall™ braces erected at 1830mm (6'-0") on center with 2.4 KPa (50 PSF) uniform load applied to a supported platform acting simultaneously with wind pressure of 0.5 KPa (10 PSF) acting against the supported insulated concrete wall form. As well, we considered a point load of 2.2 KN (500lbs) on the platform support in conjunction with the same horizontal wind pressure. All applied loads were factored in accordance with the National Building code and the Ontario Occupational Health and Safety Act.

Our analysis has resulted in limitations imposed on the range of use and erection of the PLUMB Wall™ brace. These limitations have been depicted in the attached plan. These restrictions include a maximum brace length of 2900mm (9'-6") and a minimum anchorage distance of 1000mm (3'-6") from the face of the vertical upright.

Should you have any question regarding this report, please feel free to contact our office at your convenience.

Yours truly,

D.G. Biddle &amp; Associates Ltd.

D.D. Biddle, P.Eng



## BUILDBRACE PRODUCT MANUAL

## TALL WALL ENGINEERING



Breukelman Design Inc.  
173 Kinniburgh Way,  
Chestermere, AB T1X 0R8

Reference Number: 11-040

Date: January 30, 2016

## 24' Tall Wall Adapter Test Report (Rev. 1)

The 24' Tall Wall 'Plumwall' wall brace system is designed to comply with Canadian codes and regulations. The design takes into account normal loading conditions, such as dead and live loads and wind loading.

### Summary

The design criteria for the 24' Tall Wall ICF brace system is based on the following design requirements:

CAN/CSA-S269.1, Falsework for Construction Purposes  
CAN/CSA-S269.2-M87 (R2003), *Access Scaffolding for Construction Purposes*  
CAN/CSA-S269.3-M92 (R2013), *Concrete Formwork*  
CAN/CSA A371-04 (R2014), *Masonry Construction for Buildings*  
National Building Code of Canada, 2015  
Structural Commentaries (Part 4 of Division B), NBCC 2010

For this analysis, it was assumed that the bracing would be supporting only the top 2.43 metres (8 feet) of the reinforced concrete wall design, as the bottom 16 feet will have already been placed and had a minimum cure as required by the wall design engineer or recommended in CSA 23.3-14/ACI 318-14.

The *Plumwall* brace is described as a 38mm by 38mm (1.5") steel tube inside of a 45mm by 45mm (1.75") steel tube. The brace was made of 1750mm (69") sections of each size of tube offset from each other by 500mm (20") and fully welded together. The braces were joined with 12mm (½") pins every 102mm (4") which allowed the two members to act together compositely which increases the carrying capacity of the brace. Product Limitations and Usage Requirements are included in Appendix B. Drawings of the brace assembly as tested and approved are included in Appendix C - any variation from this design will render the conclusions of this report null and void.

### Results

Through analysis of the structures geometry and specified loading cases, as provided in design assumptions, it was found that the *Plumwall* 7.3 m (24-foot) bracing would be required to carry a load of 268 kg (591 lbs). Through testing of the bracing it was demonstrated that the brace would be able support a load of 294kg (650 lbs.) This allows a conclusion that the 24-foot brace is appropriate for use in 'normal' loading situations as included in the report.

### Limitations & Usage Requirements

- Workers are expected to leave the scaffold before wind speeds reach 40 km/hour

Plumwall ICF Brace, Proton Station, ON

Page 1 of 13

## BUILDBRACE PRODUCT MANUAL

- For buildings in large open terrain and/or with very long walls, spacing between bracing must be reduced to 915mm (3').
- As per CSA A371-04 Annex D, temporary bracing should be installed using material that is maintained in good condition. Therefore, if bracing is visibly deformed before installing it is to not be used. Also, if after installing, the brace sags more than one foot (300mm) without loads applied it is to be removed and another brace that is in good condition is to be used.
- The following text is to be placed on a sticker on each brace length:

**Legal Disclaimer** (Please Read): Plumwall™ 24 Ft. Tall Wall Adapter is designed to brace Insulated Concrete Forms (ICF) for walls to 24' (7.3m) high. For full limitations refer to Plumwall™ 24 Ft. Tall Wall Adapter engineering report, available by contacting us at [www.plumwall.com](http://www.plumwall.com) or 1-888-928-6676. Tall wall braces are to be spaced a maximum of 6' apart, except at corners where the spacing shall be reduced to 3'. In cases where the tall wall is very long (>80' length) or where the wall is adjacent to an open field or parkland (for 150' distance from the new wall), the spacing shall be reduced to 3' for the length of the wall. Maximum height of 24' wall is allowed only when the first two segments(lifts) (8' and 16' heights) have been placed and have a minimum cure recommended by the wall design engineer or CSA 23.3-14/ACI 318-14. ICF brace is not intended to provide in-service structural support for any height of wall. All other required bracing (for the lower wall segments) must be maintained in addition to the tall wall brace. Adequate staking of the base of the tall wall brace is required – a minimum of 2 (two) 4' long steel stakes must be driven into the base at opposing angles to provide pullout support. If the soil conditions are sandy or soft soils, a qualified geotechnical engineer must advise as to any additional base support requirements. All workers must leave the scaffold and work-site when wind speeds reach 40 km/hr. Inspection of the brace components must be completed prior to any use and any damaged components to be replaced with undamaged components prior to use.

## Testing

Pictures are included in Appendix A to show results of testing of the tall wall brace.

Test Procedure:

1. Created connecting points at either end of the brace material, with one fixed to the ground and the other at the 20 foot connection point as specified by *Plumwall* for the bracing of the 7.3m (24') ICF wall:
  - a. On an angle as to allow brace to deform under its own weight
  - b. Not in a situation as to allow additional support, such as the ground would could act as a restraint in buckling
2. Using a tensioning device to measure axial load, initiated test by incrementally adding axial load, waiting before continuing test to allow for load to adjust for any elastic deformation.
3. Ended test when bracing deformed permanently, noting that even with permanent deformation brace still held maximum tested load.

## Design Assumptions

### 1. Load Cases

#### a. Wind Loading for 'Normal' Loading

- i. Importance Factor = 1, normal importance

Plumwall ICF Brace



## BUILDBRACE PRODUCT MANUAL

- ii. Exposure Factor = 0.5, rough terrain (suburban and urban areas)
  - iii. Gust Effect Factor = 2, main structural member
  - iv. Force Coefficient = 1.3; free standing wall on the ground with a long wall length
  - v. 1/50 Hourly Wind Pressure = 0.55 kPa, where 0.55 kPa is equal to or greater than the 1/50 wind pressure for 96% of Ontario
- b. **Live Loading for platform intended to support workers and their hand tools exclusively**
- i. A load of 3.63 kN per linear metre of platform width applied vertically and uniformly across an independent platform section along an imaginary line drawn perpendicular to the platform edge anywhere along the length of the section
  - ii. A minimum uniformly distributed load of 1.20 kN/m<sup>2</sup>, acting simultaneously with the concentrated load specified in (i)

### 2. Support Conditions

The supporting foundation is assumed to be slab-on-grade. The slab is assumed to have sufficient strength to support the wall. The wall is considered to be restrained from translation in both directions (along the wall and transverse to the wall). The base 4.87 m (16') of the 7.3m (24') wall is assumed to be cured for a minimum of 7 days, and will be able to support all of the wind loading applied to its height. The top 2.43 m (8') of the 7.3m (24') wall is assumed to hinged where it connects to the base 16 feet, allowing the wind to rotate it against the scaffold brace.

The *Plumwall* brace is assumed to be restrained against uplifting; i.e. assumed to be anchored to the slab and the surrounding soil as specified by *Plumwall*.

### 3. Material Properties

#### a. Bracing Steel

- i. Steel – 38mm x38mm x2.2mm & 45mm x45mm x2.5mm  
The brace was be made of 4' sections of each size, 45 mm wide with 38 mm wide inside, of tube offset from each other by 500mm (20"). The braces was joined with with 12mm (1/2") pins every 102mm (4").

### 4. Structural Model

#### a. Load Cases Considered

- i. Dead, D, structural self weight
- ii. Wind, W, 0.65 kN/m acting perpendicular to wall
- iii. Live, L, 7.13 kN/m acting perpendicular to scaffold platform.

#### b. Load Combinations Considered

- i. 1.25D + 1.25W + 0.5L, 1.25 wind load as per CSA A371-04 (R2014)

### Wind Load Calculation

$$\begin{aligned}
 p &= I_w C_e C_g C_r q, \text{ using assumptions shown above} \\
 &= (1.0)(0.5)(2.0)(1.3)(0.55\text{kPa}) \\
 &= 0.72\text{kPa}
 \end{aligned}$$

As per CSA A317-04, "the anticipated wind load should be assumed to be 50% of the load based on a probability of the one-in-fifty year wind pressure."

$$\begin{aligned}
 p &= 0.72\text{kPa} \times 50\% \\
 &= 0.36\text{kPa}
 \end{aligned}$$

Plumwall ICF Brace

**BUILDBRACE PRODUCT MANUAL**

$$\begin{aligned} \text{udl} &= p \times \text{tributary width, using 6 foot spacing specified by Plumwall} \\ &= 0.36\text{kPa} \times 1.83 \text{ m} \\ &= 0.66 \text{ kN/m, acting perpendicular to ICF wall being formed} \end{aligned}$$

**Live Load Calculation**

$$\begin{aligned} \text{udl}_1 &= 3.63 \text{ kN} \times 0.84 \text{ m, width of platform} \\ &= 3.05 \text{ kN/m}^2 \times 1.83 \text{ m, tributary width due to bracing spacing} \\ &= 5.6 \text{ kN/m} \end{aligned}$$

$$\begin{aligned} \text{udl}_2 &= 1.20 \text{ kN/m}^2 \times 1.83 \text{ m, tributary width due to bracing spacing} \\ &= 2.2 \text{ kN/m} \end{aligned}$$

$$\begin{aligned} \text{udl}_T &= 5.6 \text{ kN/m} + 2.2 \text{ kN/m} \\ &= 7.8 \text{ kN/m} \end{aligned}$$

**Test Results**

A total of four (4) braces were tested as outlined above with a minimum test load of 640 lbs.

Test	Test Conditions	Maximum Loading Results kN (lbs)
Analytical	Loading condition as given in appropriate codes, see above for details	2.6 (591)
1	Test was completed at specified at design length, without the use of the Tele Brace, and the adjustable brace foot	3.05 (686), consistently
2	Test was completed at specified at design length, with the use of the Tele Brace, and the adjustable brace foot	4.0 (900), consistently
3	Test was completed at specified at design length, with the use of the Tele Brace, and the adjustable brace foot	2.88 (650), consistently
4	Test was completed at specified at design length, with the use of the Tele Brace, and the adjustable brace foot	2.84 (640), consistently





Plumwall ICF Brace

## BUILDBRACE PRODUCT MANUAL





### Appendix A

Plumwall ICF Brace

**BUILDBRACE PRODUCT MANUAL**



<p>Photo 1</p>		<p>Crane Scale used to measure axial loading</p>
<p>Photo 2</p>		<p>Crane Scale used to measure axial loading</p>
<p>Photo 3</p>		<p>1.5" and 1.75" Material Used</p>
<p>Photo 4</p>		<p>5" Spacing Used between End of Member and First Pin</p>
<p>Photo 5</p>		<p>6" Spacing Used between Pins</p>

**BUILDBRACE PRODUCT MANUAL**



<p>Photo 6</p>		<p>Dimension of 1.50” Material</p>
<p>Photo 7</p>		<p>Wall Thickness of 1.50” Material</p>
<p>Photo 8</p>		<p>Dimension of 1.75” Material</p>
<p>Photo 9</p>		<p>Wall Thickness of 1.75” Material</p>

**BUILDBRACE PRODUCT MANUAL**

**Test #1**

<p>Photo 10</p>		<p>Test #1 Set Up</p>
<p>Photo 11</p>		<p>Ground Level Connection</p>
<p>Photo 12</p>		<p>Test #1 Set Up</p>

**BUILDBRACE PRODUCT MANUAL**

<p>Photo 13</p>		<p>Deformation after Test Completion</p>
<p>Photo 14</p>		<p>Deformation after Test Completion</p>

**Test #2**

<p>Photo 15</p>		<p>Test #2 Set Up</p>
<p>Photo 16</p>		<p>Test #2 Set Up</p>



**BUILDBRACE PRODUCT MANUAL**

<p>Photo 17</p>		<p>Crane Scale Connection</p>
<p>Photo 18</p>		<p>Deformation After Completion of Test with Load Applied</p>
<p>Photo 19</p>		<p>Deformation After Completion of Test with Load Removed</p>
<p>Photo 20</p>		<p>904 lbs Maximum Load</p>



**BUILDBRACE PRODUCT MANUAL**

**Test: #3**

<p>Photo 21</p>		<p>Test #3 Set Up</p>
<p>Photo 22</p>		<p>652 lbs Maximum Load</p>

## BUILDBRACE PRODUCT MANUAL

### Appendix B

Plumwall ICF Brace

## BUILDBRACE PRODUCT MANUAL



## Limitations & Usage Requirements

- This “Limitation & Usage Requirements” page shall be included with each brace system. Reference to these limitations and usage requirements shall be affixed to each brace component.
- Contractor to maintain inspection logs and an employee/contractor sign-off/training log for the use of this product. All workers utilizing this bracing system shall be given usage/safety training prior to accessing the system. Appropriate fall-arrest systems shall be utilized as required during access, setup and removal of the bracing system.
- Workers are expected to leave the scaffold before wind speeds reach 15 m/s (~50 km/h, 35mph).
- Concrete pump operators are to ensure that the boom or hoses do not come into contact with the ICF formwork. Any contact of the boom/hoses with the ICF formwork or brace may cause damage to the formwork and/or the bracing system.
- For buildings in open terrain and/or with very long walls, spacing between bracing must be reduced to 3 feet. Reduced spacing may also be required for situations where soil conditions prevent a solid connection to the ground. A licensed & qualified professional engineer shall be consulted if any concerns exist with respect to base support conditions.
- Anchorage of the base plate to ground shall be capable of transferring any uplift forces (tension) in the braces. This is particularly true for sandy soil conditions where the anchor stakes may have little resistance to withdrawal. A licensed & qualified professional engineer shall be consulted if any concerns exist with respect to base support conditions.
- Poor soil conditions will reduce the capacity of the bracing system. Contractor takes full responsibility for ensuring the base support condition is adequate. A licensed & qualified professional engineer shall be consulted if any concerns exist with respect to base support conditions.
- As per A317-04 Annex D, temporary bracing should be installed using material that is maintained in good condition. Therefore, if bracing is visibly deformed before installing it is to not be used. Also, if after installing, the brace deforms more than one foot without loads applied it is to be removed and another brace that is in good condition is to be used.



## BUILDBRACE PRODUCT MANUAL

### Appendix C

Plumwall ICF Brace

BUILDBRACE PRODUCT MANUAL

ITEM NO.	PART NUMBER	DESCRIPTION
1	PLMBRACE-A201	Assembled Adaptor Section
2	PLMBRACE-W200	
3	PLMBRACE-L106	
4	PLMBRACE-A202	
5	PLMBRACE-W205	Brace Tube Section
6	PLMBRACE-W206	Brace Tube Section
8	PLMBRACE-A108	Foot Tube Assembly
11	PLMBRACE-A106	Pin

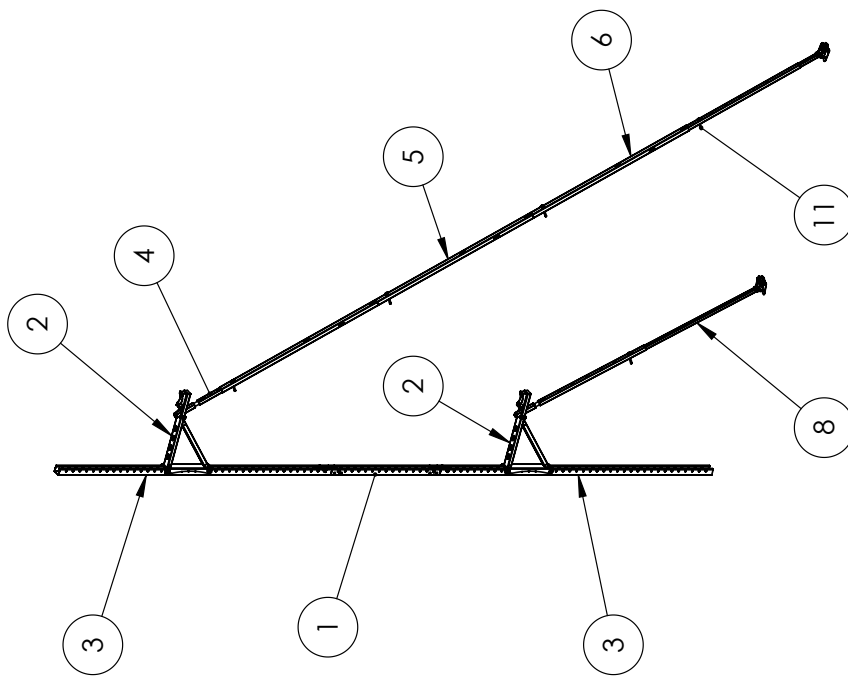

CAD DETAILS

REV DATE: 2013-05-01  
 AUTHOR: Mathlon M.

REV

PART NO. PLMBRACE-A210  
 TITLE: 24FT Brace

WEIGHT: 209.84  
 SCALE: 1:64  
 SHEET 1 OF 1

DO NOT SCALE DRAWING  
 UNLESS OTHERWISE SPECIFIED  
 DIMENSIONS ARE IN INCHES  
 FRACTIONAL: +/- 1/32  
 .000 DECIMAL: +/- 0.005  
 ANGULAR: +/- 0.5°

MATERIAL: As Per Part

QUANTITY:



Proton Station  
 Ontario, Canada  
 Ph: 888-928-6676  
 Fax: 519-923-2602  
 sales@plumwall.com  
 www.plumwall.com

BUILDBRACE PRODUCT MANUAL

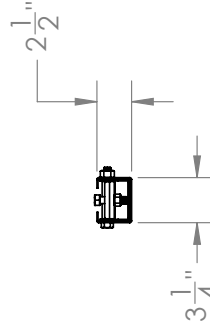
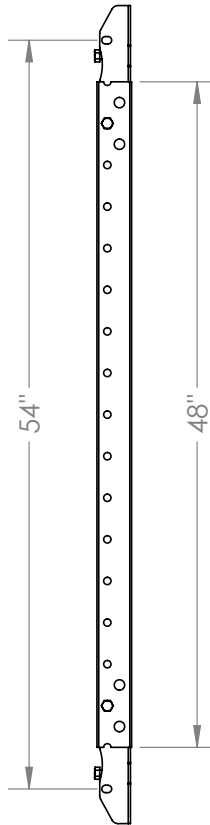
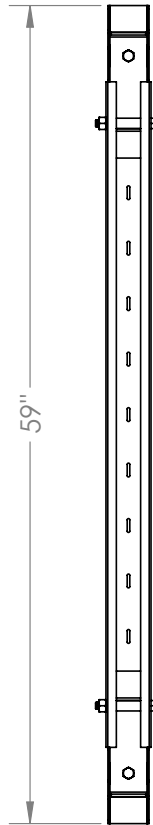
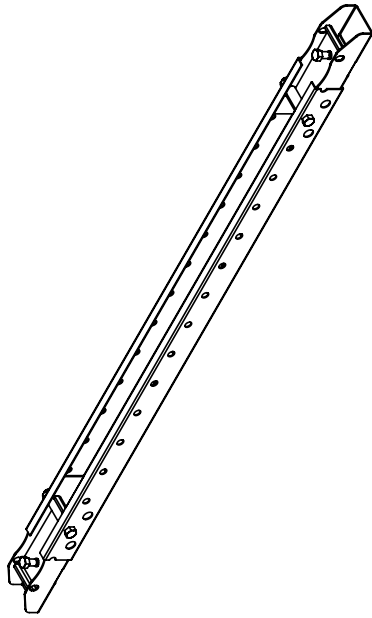

Proton Station  
 Ontario, Canada  
 Ph: 888-928-6676  
 Fax: 519-923-2602  
 sales@plumwall.com  
 www.plumwall.com



REV DATE:  
 2013-04-30  
 AUTHOR:  
 MATHION M.

REV

PART NO.

PLMBRACE-A201

TITLE: Assembled Adaptor Section

WEIGHT:  
 16.80

SCALE: 1:12

SHEET 1 OF 1

MATERIAL:  
 As Per Part

QUANTITY:  
 UNLESS OTHERWISE SPECIFIED  
 DIMENSIONS ARE IN INCHES  
 FRACTIONAL: +/- 1/32  
 DECIMAL: +/- 0.005  
 ANGULAR: +/- 0.5°

BUILDBRACE PRODUCT MANUAL

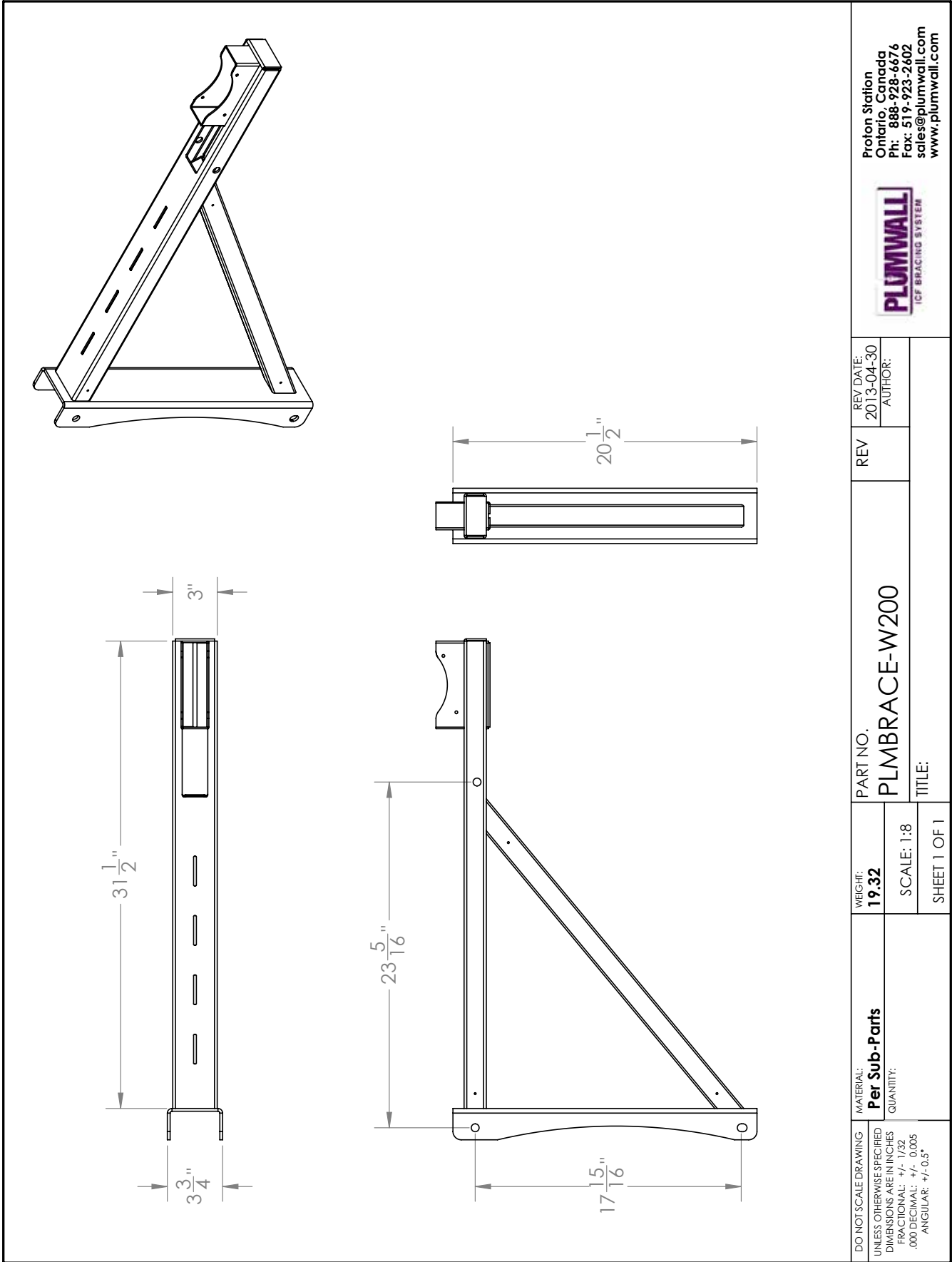

Proton Station  
 Ontario, Canada  
 Ph: 888-928-6676  
 Fax: 519-923-2602  
 sales@plumwall.com  
 www.plumwall.com



REV DATE:  
 2013-04-30  
 AUTHOR:

REV

PART NO.  
**PLMBRACE-W200**

WEIGHT:  
**19.32**

SCALE: 1:8

SHEET 1 OF 1

TITLE:

MATERIAL:  
**Per Sub-Parts**  
 QUANTITY:

DO NOT SCALE DRAWING  
 UNLESS OTHERWISE SPECIFIED  
 DIMENSIONS ARE IN INCHES  
 FRACTIONAL: +/- 1/32  
 .000 DECIMAL: +/- 0.005  
 ANGULAR: +/- 0.5°

BUILDBRACE PRODUCT MANUAL

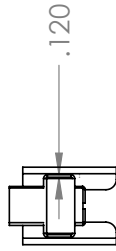
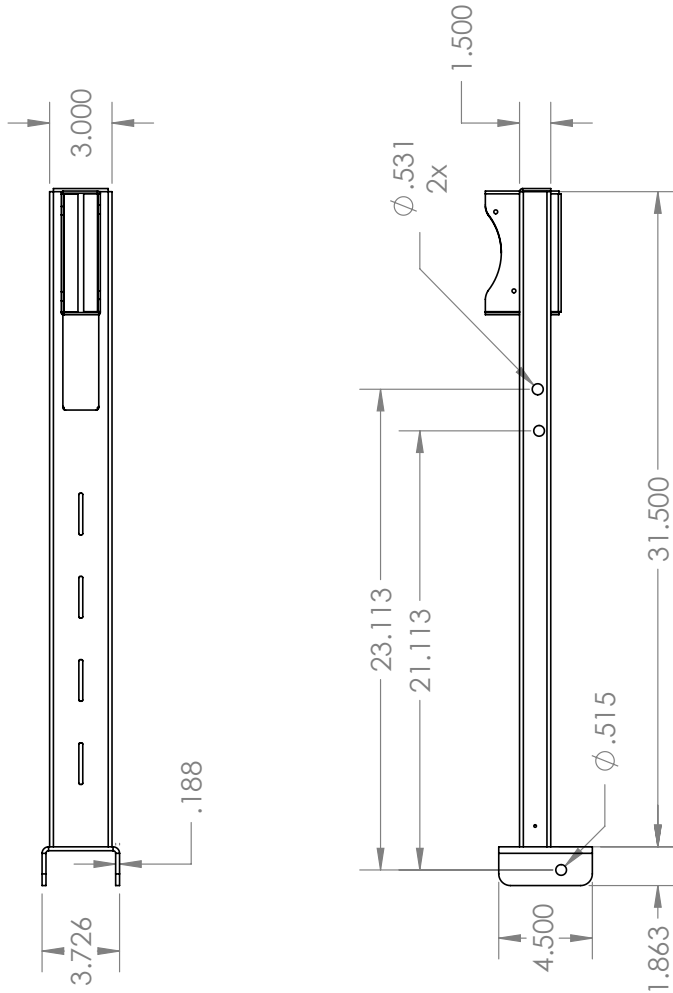
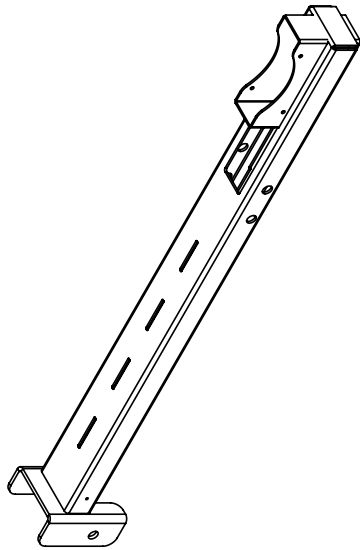

Proton Station  
 Ontario, Canada  
 Ph: 888-928-6676  
 Fax: 519-923-2602  
 sales@plumwall.com  
 www.plumwall.com



REV DATE:  
 2013-04-18  
 AUTHOR:

REV

PART NO.  
**PLMbrace-W201**

WEIGHT:  
 SCALE: 1:8  
 SHEET 1 OF 1

TITLE:

DO NOT SCALE DRAWING  
 UNLESS OTHERWISE SPECIFIED  
 DIMENSIONS ARE IN INCHES  
 FRACTIONAL: +/- 1/32  
 DECIMAL: +/- 0.005  
 ANGULAR: +/- 0.5°



**BUILDBRACE PRODUCT MANUAL**

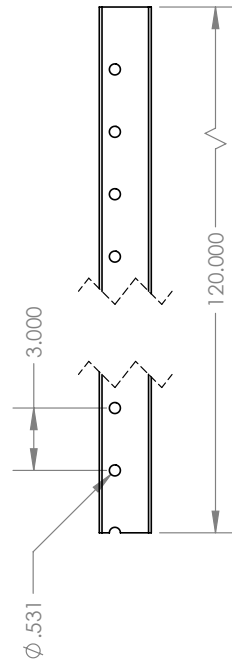
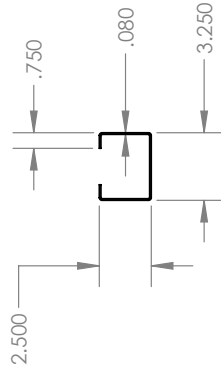
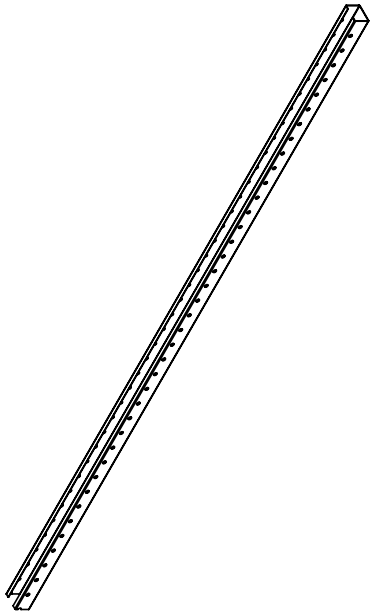

Proton Station  
 Ontario, Canada  
 Ph: 888-928-6676  
 Fax: 519-923-2402  
 sales@plumwall.com  
 www.plumwall.com



REV DATE:  
 2013-04-18  
 AUTHOR:  
 ASManilla

REV

PART NO.  
**PLMbrace-L106**

WEIGHT:  
**24.834**  
 SCALE: 1:8  
 SHEET 1 OF 1

MATERIAL:  
**Galvanized Steel**  
 QUANTITY:

DO NOT SCALE DRAWING  
 UNLESS OTHERWISE SPECIFIED  
 DIMENSIONS ARE IN INCHES  
 FRACTIONAL: +/- 1/32  
 .000 DECIMAL: +/- 0.005  
 ANGULAR: +/- 0.5°

TITLE:

BUILDBRACE PRODUCT MANUAL

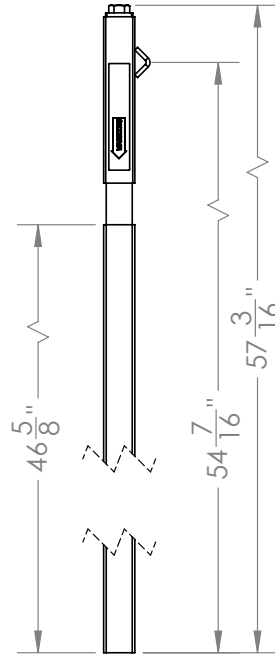
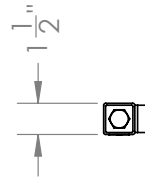
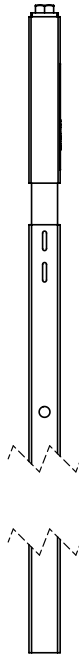
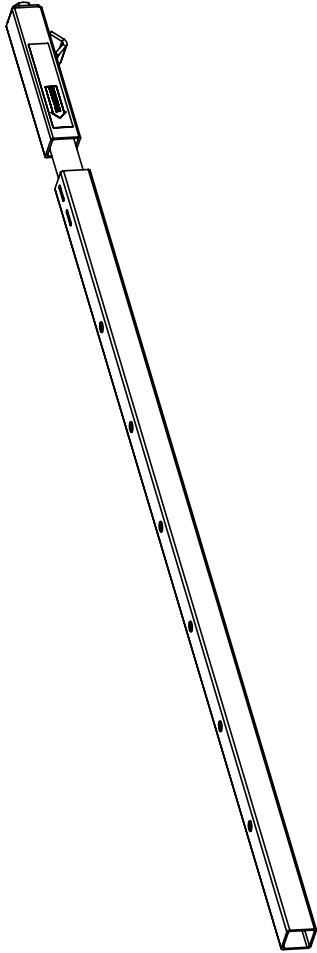

Proton Station  
 Ontario, Canada  
 Ph: 888-928-6676  
 Fax: 519-923-2602  
 sales@plumwall.com  
 www.plumwall.com



REV DATE:  
 2013-04-30  
 AUTHOR:

REV

PART NO.

PLMbrace-A202

TITLE:

WEIGHT:

SCALE: 1:8

SHEET 1 OF 1

MATERIAL:

QUANTITY:

DO NOT SCALE DRAWING  
 UNLESS OTHERWISE SPECIFIED  
 DIMENSIONS ARE IN INCHES  
 FRACTIONAL: +/- 1/32  
 .000 DECIMAL: +/- 0.005  
 ANGULAR: +/- 0.5°

BUILDBRACE PRODUCT MANUAL

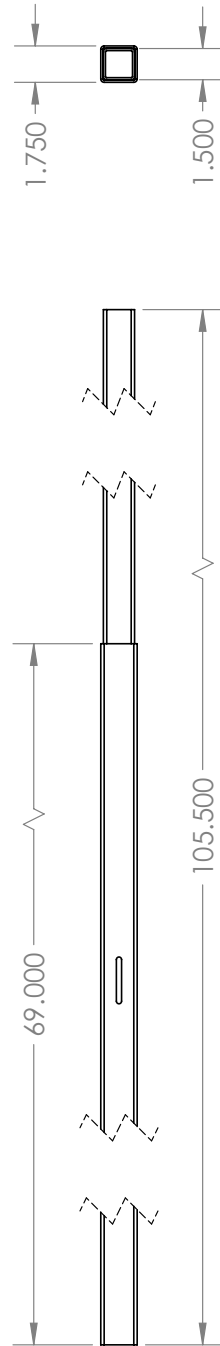
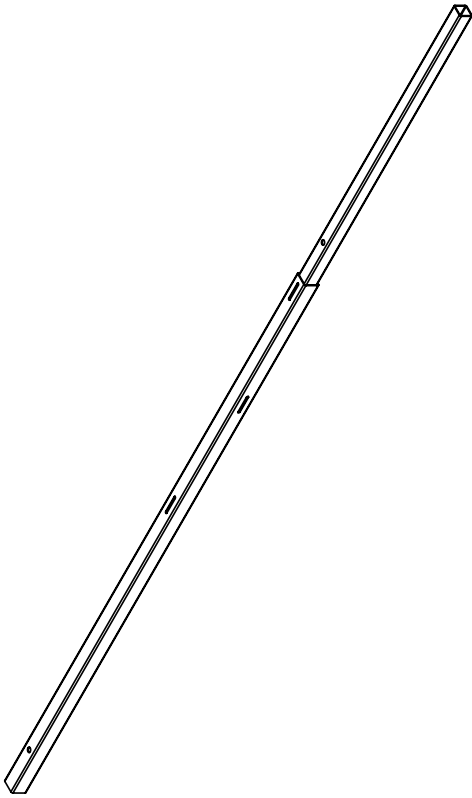

Proton Station  
 Ontario, Canada  
 Ph: 888-928-6676  
 Fax: 519-923-2602  
 sales@plumwall.com  
 www.plumwall.com



REV DATE:  
 2013-04-30  
 AUTHOR:  
 MATHION M.

REV

PART NO.

PLMbrace-W205

TITLE: Brace Tube Section

WEIGHT:  
 23.06

SCALE: 1:8

SHEET 1 OF 1

MATERIAL:  
 As Per Part

QUANTITY:

DO NOT SCALE DRAWING  
 UNLESS OTHERWISE SPECIFIED  
 DIMENSIONS ARE IN INCHES  
 FRACTIONAL: +/- 1/32  
 .000 DECIMAL: +/- 0.005  
 ANGULAR: +/- 0.5°

BUILDBRACE PRODUCT MANUAL

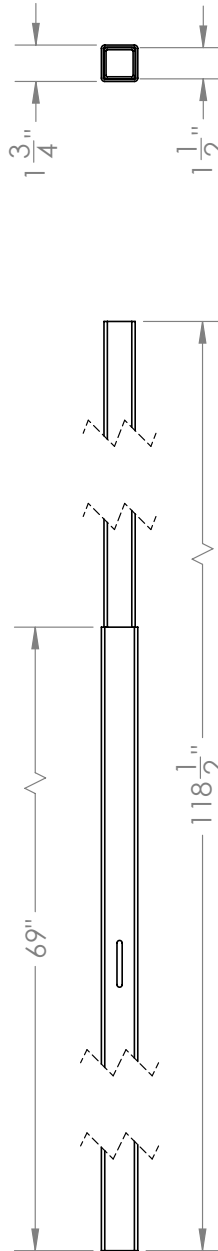
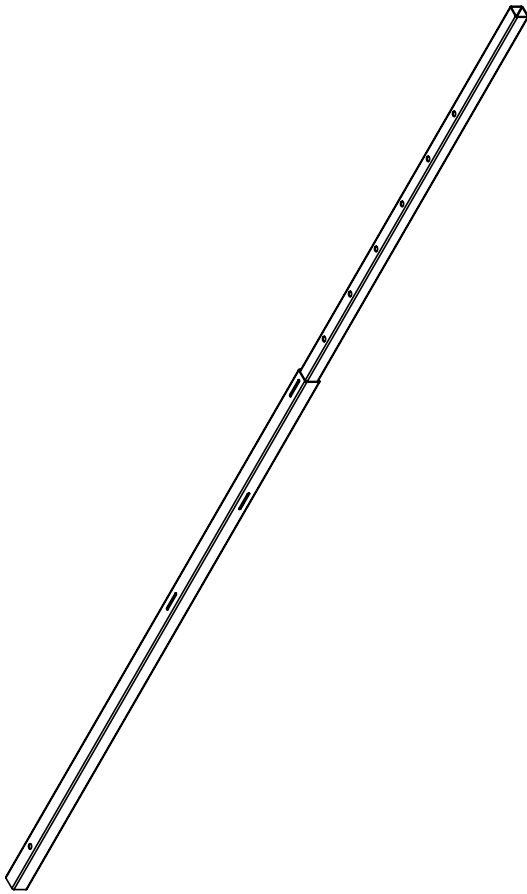

Proton Station  
 Ontario, Canada  
 Ph: 888-928-6676  
 Fax: 519-923-2402  
 sales@plumwall.com  
 www.plumwall.com



REV DATE:	2013-04-30
AUTHOR:	MOTION M.

REV	
-----	--

PART NO.	PLMBRACE-W206
TITLE:	Brace Tube Section

WEIGHT:	24.99
SCALE:	1:8
SHEET	1 OF 1

MATERIAL:	As Per Part
QUANTITY:	

DO NOT SCALE DRAWING  
 UNLESS OTHERWISE SPECIFIED  
 DIMENSIONS ARE IN INCHES  
 FRACTIONAL: +/- 1/32  
 .000 DECIMAL: +/- 0.005  
 ANGULAR: +/- 0.5°

BUILDBRACE PRODUCT MANUAL

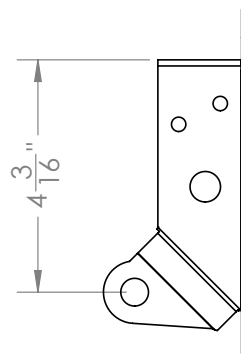
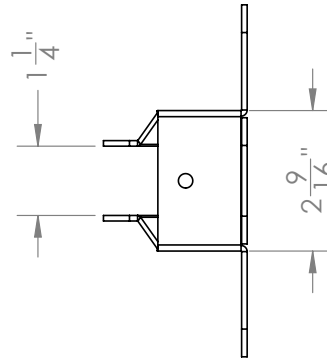
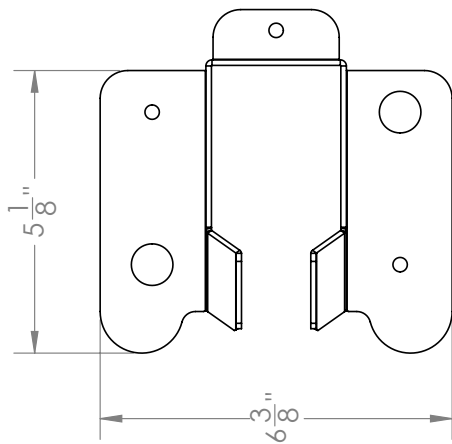
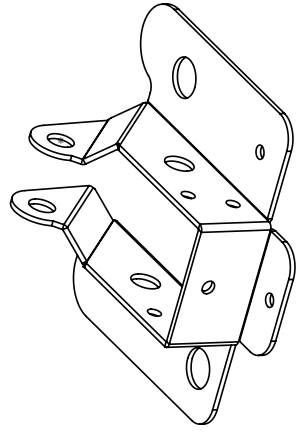

Proton Station  
 Ontario, Canada  
 Ph: 888-928-6676  
 Fax: 519-923-2602  
 sales@plumwall.com  
 www.plumwall.com



REV DATE:  
 2013-04-30  
 AUTHOR:  
 ASManilla

REV

PART NO.  
**PLMbrace-L107**

WEIGHT:  
**0.1437**  
 SCALE: 1:3  
 SHEET 1 OF 1

MATERIAL:  
**Material <not specified>**  
 QUANTITY:

DO NOT SCALE DRAWING  
 UNLESS OTHERWISE SPECIFIED  
 DIMENSIONS ARE IN INCHES  
 FRACTIONAL: +/- 1/32  
 .000 DECIMAL: +/- 0.005  
 ANGULAR: +/- 0.5°

TITLE:

BUILDBRACE PRODUCT MANUAL

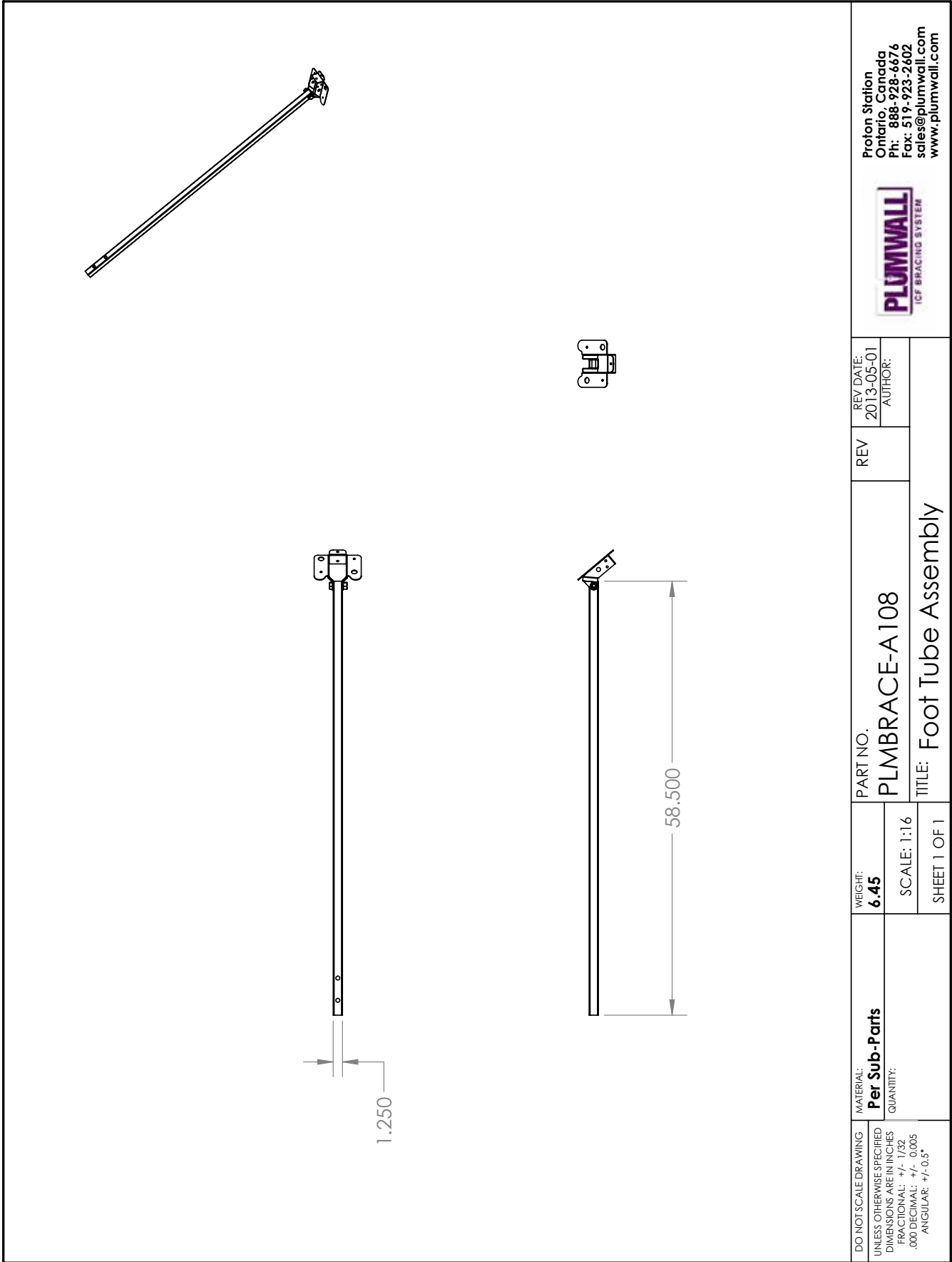

Proton Station  
 Ontario, Canada  
 Ph: 888-928-6676  
 Fax: 519-923-2402  
 sales@plumwall.com  
 www.plumwall.com



DO NOT SCALE DRAWING UNLESS OTHERWISE SPECIFIED DIMENSIONS ARE IN INCHES FRACTIONAL: +/- 1/32 .000 DECIMAL: +/- 0.005 ANGULAR: +/- 0.5°	MATERIAL: <b>Per Sub-Parts</b>	WEIGHT: <b>6.45</b>	PART NO. <b>PLMBRACE-A108</b>	REV	REV DATE: 2013-05-01
	QUANTITY:	SCALE: 1:16	TITLE: Foot Tube Assembly		AUTHOR:
		SHEET 1 OF 1			

BUILDBRACE PRODUCT MANUAL

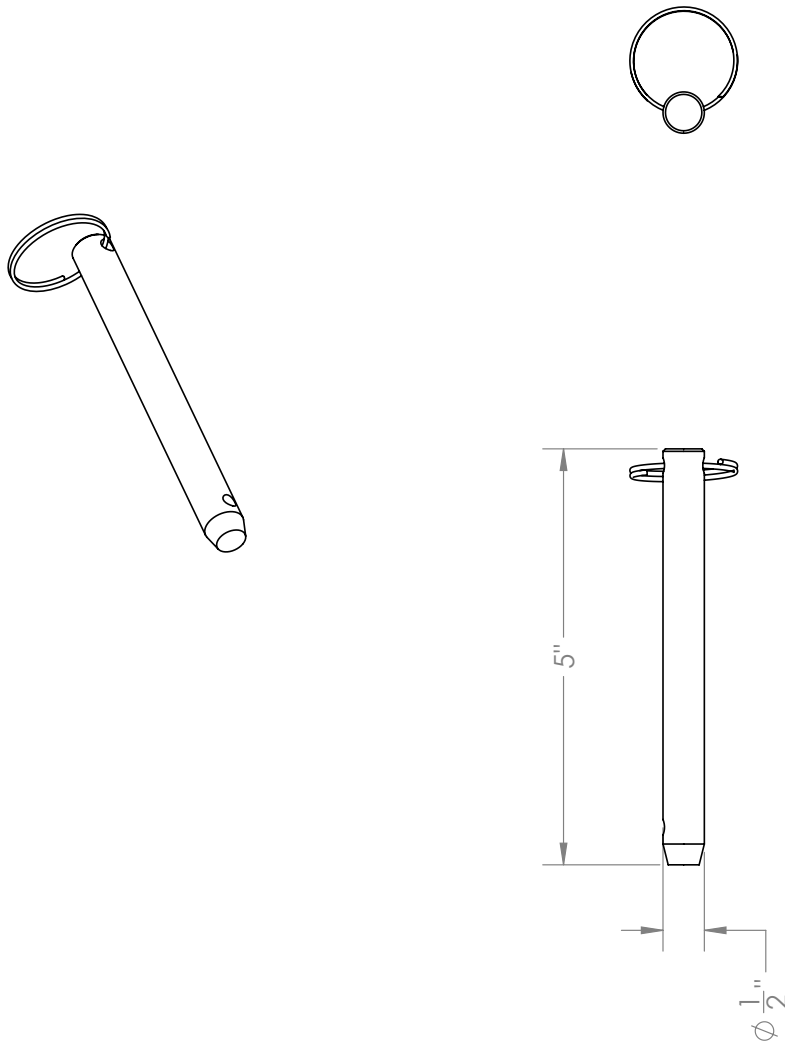

Proton Station  
 Ontario, Canada  
 Ph: 888-928-6676  
 Fax: 519-923-2402  
 sales@plumwall.com  
 www.plumwall.com



REV DATE:  
 2013-05-01  
 AUTHOR:  
 MATHION M.

REV

PART NO.  
**PLMBRACE-A106**

TITLE:  
**Pin**

WEIGHT:  
**0.27**

SCALE: 1:2

SHEET 1 OF 1

MATERIAL:  
**As Per Part**  
 QUANTITY:

DO NOT SCALE DRAWING  
 UNLESS OTHERWISE SPECIFIED  
 DIMENSIONS ARE IN INCHES  
 FRACTIONAL: +/- 1/32  
 .000 DECIMAL: +/- 0.005  
 ANGULAR: +/- 0.5°



## NORTH AMERICAN MANUFACTURING FACILITIES

BuildBlock Building Systems has fourteen manufacturing facilities across North America and plans to add locations for the next several years. This means we have the manufacturing capacity to meet your ICF needs now and in the future. Shorter shipping distances mean lower freight costs for you and your customers.

BuildBlock continually develops new products and technologies solving problems and meeting needs in residential, commercial, industrial, and institutional construction. We innovate with the goal of creating cost-effective techniques and products for our customers.

BuildBlock partners have facilities around the world to meet your needs including the Philippines, Cyprus, and Egypt and continue to expand. Choosing BuildBlock isn't just about choosing the best ICF block on the market, it's about finding a partner with a strong commitment to our customers, our business partners, and our industry.

### CONTACT BUILDBLOCK

☎ 866-222-2575 Toll free	🌐 <a href="http://buildblock.com">buildblock.com</a>
☎ 405-840-3386 Office	🛒 <a href="http://store.buildblock.com">store.buildblock.com</a>
☎ 831-597-0792 Fax	🎓 <a href="http://training.buildblock.com">training.buildblock.com</a>

### SOCIAL MEDIA



## MISSION

To harmoniously use the extraordinary gifts and talents of our distributors and dealers to fulfill the goals and dreams of millions of people who want to build better structures as reflected by our motto: "Build it once. Build it for life."

To manufacture one of the most affordable and highest quality Insulating Concrete Forms available in the world today.

To build greatness by providing the resources and services needed for building successful ICF businesses and sustainable ICF structures.

To build an enduring, profitable company while conducting business with Godly character, fairness and integrity.

## VISION

We envision a world where BuildBlock ICF technology delivers energy-efficient, safe, healthy, comfortable and sustainable ICF homes and buildings to millions of people worldwide through the uncompromising integrity of BuildBlock's team of distributors, dealers and customers.

## VALUES

**INTEGRITY** – We strive to balance the best interests of our distributors, dealers, customers, employees, and investors in an environment of Godly character and honesty.

**EDUCATION** – We seek to educate the public on the valuable benefits of ICF structures while recognizing that in order to expand the industry, we must educate installers, architects, and engineers in ICF best practices.

**CUSTOMER SATISFACTION** – We commit to building a team of employees that is inspired, empowered, and driven to meet the ever-changing needs of our distributors, dealers, and customers while we seek to distinguish ourselves in the marketplace by delivering exceptional customer satisfaction.

**INNOVATION** – We value and invest heavily in innovation while continually expanding our product line through the development of technologically advanced products.

**QUALITY** – We commit to producing the finest quality products. We stand by the belief that our brand embodies quality, consistency, user satisfaction, and service.

**PROFITABILITY** – We commit to the strong work ethic and financial prudence necessary to deliver financial results for our business partners and investors and to ensure a long-term profitable relationship.

**EMPOWERMENT** – We dedicate ourselves to empowering people to improve and enrich their lives and the world around them.